

POWER CLAMP SENSOR

**POWER CLAMP SENSOR Series**

**MODEL 8124/8125/8126/8127**

**KYORITSU ELECTRICAL INSTRUMENTS WORKS, LTD., TOKYO, JAPAN**

**1. Safety warnings**

○ This instrument has been designed, manufactured and tested according to IEC 61010: Safety requirements for Electronic Measuring apparatus, and delivered in the best condition after passing quality control tests. This instruction manual contains warnings and safety rules which have to be observed by the user to ensure safe operation of the instrument and to maintain it in safe condition. Therefore, read through these operating instructions before using the instrument.

**⚠ WARNING**

- Read through and understand instructions contained in this manual before using the instrument.
- Keep the manual at hand to enable quick reference whenever necessary.
- The instrument is to be used only in its intended applications. The operating instructions described in the manual must be observed.
- Understand and follow all the safety instructions contained in the manual. It is essential that the above instructions are adhered to. Failure to follow the above instructions may cause injury and or instrument damage.

○ The symbol ⚠ indicated on the instrument, means that the user must refer to the related parts in the manual for safe operation of the instrument. It is essential to read the instructions wherever the ⚠ symbol appears in the manual.

- ⚠ **DANGER** is reserved for conditions and actions that are likely to cause serious or fatal injury.
- ⚠ **WARNING** is reserved for conditions and actions that can cause serious or fatal injury.
- ⚠ **CAUTION** is reserved for conditions and actions that can cause minor injury or instrument damage.

- ⚠ **DANGER**
  - Never make measurement on a circuit in which the electrical potential exceeds AC300V using MODEL8127 and AC600V using MODEL8124, 8125 and 8126.
  - Do not make measurement when thunder rumbling. If the instrument is in use, stop the measurement immediately and remove the instrument from the measured object.
  - Do not attempt to make measurement in the presence of flammable gasses. Otherwise, the use of the instrument may cause sparking, which can lead to an explosion.
  - The transformer jaws are made of metal and their tips are not completely insulated. Be especially careful about the possible shorting where the measured object has exposed metal parts.
  - Never attempt to use the instrument if it's surface or your hand are wet.
  - Do not exceed the maximum allowable input of any measuring range.

- ⚠ **WARNING**
  - Never attempt to make any measurement, if any abnormal conditions are noted, such as broken case, and exposed metal parts.
  - Do not install substitute parts or make any modification to the instrument. Return the instrument to the distributor from who you purchased this instrument for repair or re-calibration in case of suspected faulty operation.
  - Always keep your fingers and hands behind the barrier on the instrument to avoid the possible shock hazard.

- ⚠ **CAUTION**
  - Do not step on or pinch the cord to prevent the jacket of cord from being damaged.
  - The output connector shall be removed or connected without clamping a conductor. Otherwise, it may cause a failure.
  - Do not expose the instrument to direct sunlight, high temperatures, humidity or dew.
  - Never give shocks, such as vibration or drop, which may damage the instrument.
  - Use a damp cloth and detergent for cleaning the instrument. Do not use abrasives or solvents.

**Safety symbols**

⚠	Refer to the instructions in the manual.
□	Indicates a Instrument with double or reinforced insulation
⚡	Indicates that this instrument can clamp on bare conductors.
~	Indicates AC

**2. Features**

- This is a clamp sensor for our Power meter.
- Designed to international safety standard IEC61010-2-032 CAT. III Pollution Degree 2

**3. Instrument layout**

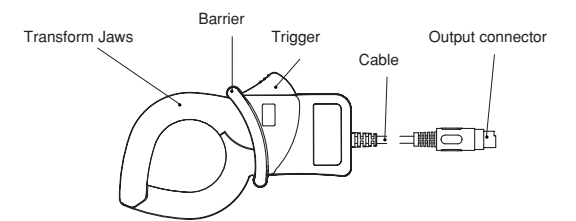

**4. Din plug pin assignment**

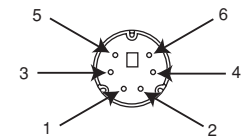

3: GND pin  
5: Output signal pin  
1, 2, 4 and 6: No use

\*Above figure shows the pin assignment seeing the Clamp sensor from output connector part. The figure of the pin assignment of connection terminal is symmetrical to above figure.

**5. Specifications**

Model	8124	8125	8126	8127
Rated voltage	AC1000Arms(1414Apeak)	AC500Arms(707Apeak)	AC200Arms(283Apeak)	AC100Arms(141Apeak)
Output voltage	AC0~500mV (AC500mV/AC1000A):0.5mV/A	AC0~500mV (AC500mV/AC500A):1mV/A	AC0~500mV (AC500mV/AC200A):2.5mV/A	AC0~500mV (AC500mV/AC100A):5mV/A
Measuring range	AC0~1000A	AC0~500A	AC0~200A	AC0~100A
Accuracy (Input: sine wave)	±0.5%rdg±0.2mV(50/60Hz) ±1.5%rdg±0.4mV(40~1kHz)	±0.5%rdg±0.1mV(50/60Hz) ±1.0%rdg±0.2mV(40~1kHz)	±0.5%rdg±0.1mV(50/60Hz) ±1.0%rdg±0.2mV(40~1kHz)	±0.5%rdg±0.1mV(50/60Hz) ±1.0%rdg±0.2mV(40~1kHz)
Phase characteristics	±1deg within(at 10~1000A / 45~65Hz)	±1deg within(at 5~500A / 45~65Hz)	±1deg within(at 2~200A / 45~65Hz)	±2deg within(at 1~100A / 45~65Hz)
Temperature & humidity range (Guaranteed accuracy)	23±5°C, relative humidity: 85% or less (no condensation)			
Operating temperature range	0~50°C, relative humidity: 85% or less (no condensation)			
Storage temperature range	-20~60°C, relative humidity: 85% or less (no condensation)			
Maximum permissible input	AC1000Arms continuous (50/60Hz)	AC500Arms continuous (50/60Hz)	AC200Arms continuous (50/60Hz)	AC100Arms continuous(50/60Hz)
Output impedance	Approx. 1 Ω	Approx. 2 Ω	Approx. 5 Ω	Approx. 11 Ω
Location for use	Altitude up to 2000m, Indoors			
Applicable standards	IEC 61010-1, IEC 61010-2-032 Measurement CAT. III (600Vrms) Pollution degree 2 IEC 61326		IEC 61010-1, IEC 61010-2-032 Measurement CAT. III (300Vrms) Pollution degree 2 IEC 61326	
Withstand voltage	AC5350Vrms (50/60Hz)for 5 sec. between Jaw and enclosure between enclosure and output terminal between Jaw and output terminal		AC3320Vrms (50/60Hz)for 5 sec. between Jaw and enclosure between enclosure and output terminal between Jaw and output terminal	
Insulation resistance	50MΩ or greater at 1000V between Jaw and enclosure between enclosure and output terminal between Jaw and output terminal			
Conductor Size	Approx.68mm in diameter (max.)	Approx.40mm in diameter (max.)	Approx.40mm in diameter (max.)	Approx.24mm in diameter (max.)
Dimension	186(L)×129(W)×53(D)mm	128(L)×81(W)×36(D)mm	128(L)×81(W)×36(D)mm	100(L)×60(W)×26(D)mm
Cable length	Approx. 3m			
Output terminal	MINI DIN 6PIN			
Weight	Approx. 510g	Approx. 260g	Approx. 260g	Approx. 160g
Accessories	Instruction manual Cable marker			
Option	MODEL 7146 (Banans Φ4 adjuster plug) MODEL 7147 (Extension cable)			

**6. Operating instructions**

- ⚠ **DANGER**
  - Never make measurement on a circuit in which the electrical potential exceeds AC300V using MODEL8127 and AC600V using MODEL8124, 8125 and 8126 in order to avoid possible shock hazard.
  - The transformer jaws are made of metal and their tips are not completely insulated. Be especially careful about the possible shorting where the measured object has exposed metal parts.

- ⚠ **CAUTION**
  - Take sufficient care to avoid shock, vibration or excessive force when handling the instrument. Otherwise, precisely adjusted transformer jaws will be damaged.
  - When transformer jaws do not fully close, never try to close them by force, but make them free to move and try again. If a foreign substance is stuck in the jaw tips, remove it.
  - When making current measurements, keep the transformer jaws fully closed. Otherwise, accurate measurements cannot be taken. Maximum conductor size is as follows.  
MODEL8124 : 68mm in diameter  
MODEL8125/ 8126: 40mm in diameter  
MODEL8127 : 24mm in diameter
  - Hold the inserting part (except for the cable) and disconnect the Output connector from the measuring instrument so as not to cause a break in the cord.

**6-1 Measurement procedures**

- (1) Connect the Output connector to the Input terminal of the measuring instrument.
- (2) Press the Trigger to open the transformer jaws and clamp onto one conductor. In this case, the measured conductor shall be at the center of the jaws. When connecting a sensor with a Power meter (our Power meter, MODEL6300, etc.) match the arrow mark

(Power source to load), which is indicated on the transformer jaws, with the current flowing direction in order to synchronize the phases of measured current and output voltage.

- (3) Ensure that the tips of transformer jaws are firmly closed.

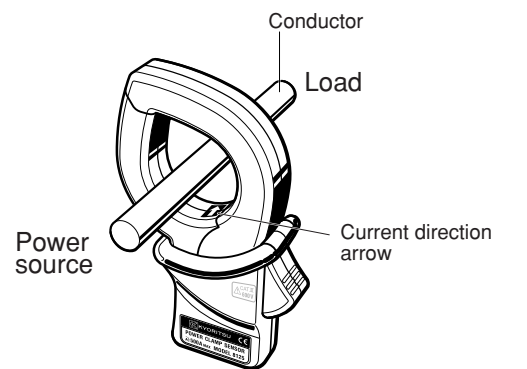

**6-2 Setting for MODEL6300 Power meter**

Refer to the table below when using these clamp sensors with MODEL6300. It shows the settings for clamp sensor and available current ranges on MODEL6300.

For further details on the settings, see the instruction manual for MODEL6300.

MODEL	Setting for MODEL6300	
	Type of Clamp sensor	Current range
MODEL8124	1000 A	100/200/500/1000 A
MODEL8125	500 A	50/100/200/500 A
MODEL8126	200 A	20/50/100/200 A
MODEL8127	100 A	10/20/50/100 A

**DISTRIBUTOR**

Kyoritsu reserves the rights to change specifications or designs described in this manual without notice and without obligations.



**PEWA**  
Messtechnik GmbH

Weidenweg 21  
58239 Schwerte

Tel.: 02304-96109-0

Fax: 02304-96109-88

E-Mail: info@pewa.de

Homepage : www.pewa.de