

## Model 3269

### Adapter – BNC Female To Miniature Double Banana Plug

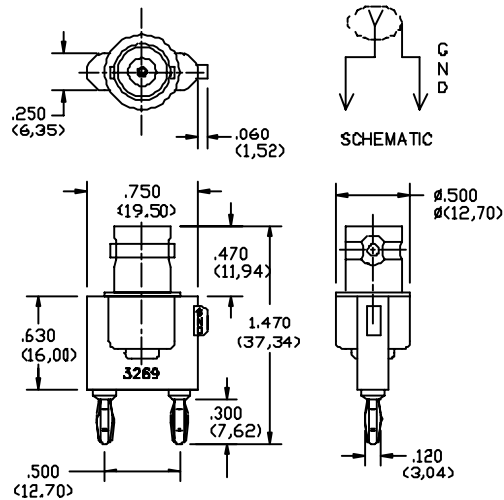

#### FEATURES:

- Allows a BNC male to be used with equipment having .5" (12,7) spaced miniature .104" (2,4) dia. banana jacks
- Excellent for adapting test equipment to BNC coaxial cables

#### MATERIALS:

Upper Conn: BNC Female.

Finish: Tarnish Resistant

Center Contact: Gold plated

Insulation: ABS molded to BNC male and Banana Plug

Color: Black

Marking: "POMONA ELECTRONICS CALIF. 3269"

Lower Conn: Miniature Double Banana Plug

Material: Spring, Beryllium Copper

Plug Body: Brass

Finish: Gold plated

#### RATINGS:

Operating Temperature: +50° C. (+122° F.) Max.

Operating Voltage: Hand-Held Testing: 30VAC/60VDC Max.

Hands Free Testing in controlled voltage environments: 500 VRMS Max.

#### ORDERING INFORMATION: Model 3269

All dimensions are in inches. Tolerances (except noted): .xx = ±.02" (.51 mm), .xxx = ±.005" (.127 mm).

All specifications are to the latest revisions. Specifications are subject to change without notice.

Registered trademarks are the property of their respective companies. Made in USA

Sales: 800-490-2361 Fax: 888-403-3360  
Technical Assistance: 800-241-2060

PomonaACCESS 90572 (800) 444-6785 or (425) 446-6010  
More drawings available at [www.pomonaelectronics.com](http://www.pomonaelectronics.com)