

Model 3533
Adapter
BNC Male To Male

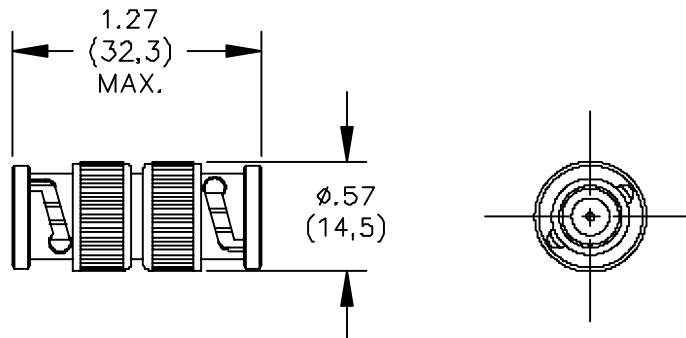

MATERIALS:

Body – Brass, Tarnish Resistant Plating, Center Contact: Gold Plated Brass

Dielectric: PTFE

Finish: Body and Fittings – Tarnish Resistant

Center Contact – Gold Plated

Marking: “Pomona 3533”

RATING:

Operating Voltage: Shield/Earth: 30VAC/60VDC Max.

Inner Conductor/Shield: 500VRMS Max.

Operating Temperature: -65°C to +165°C

Nominal Impedance: 50 Ohms

ORDERING INFORMATION: Model 3533

All dimensions are in inches and metric. All specifications are to the latest revisions. Specifications are subject to change without notice.
Registered trademarks are the property of their respective companies. Made in USA