

Model 3601 & 3606
Die Cast Aluminum Box
Painted, Size "D"

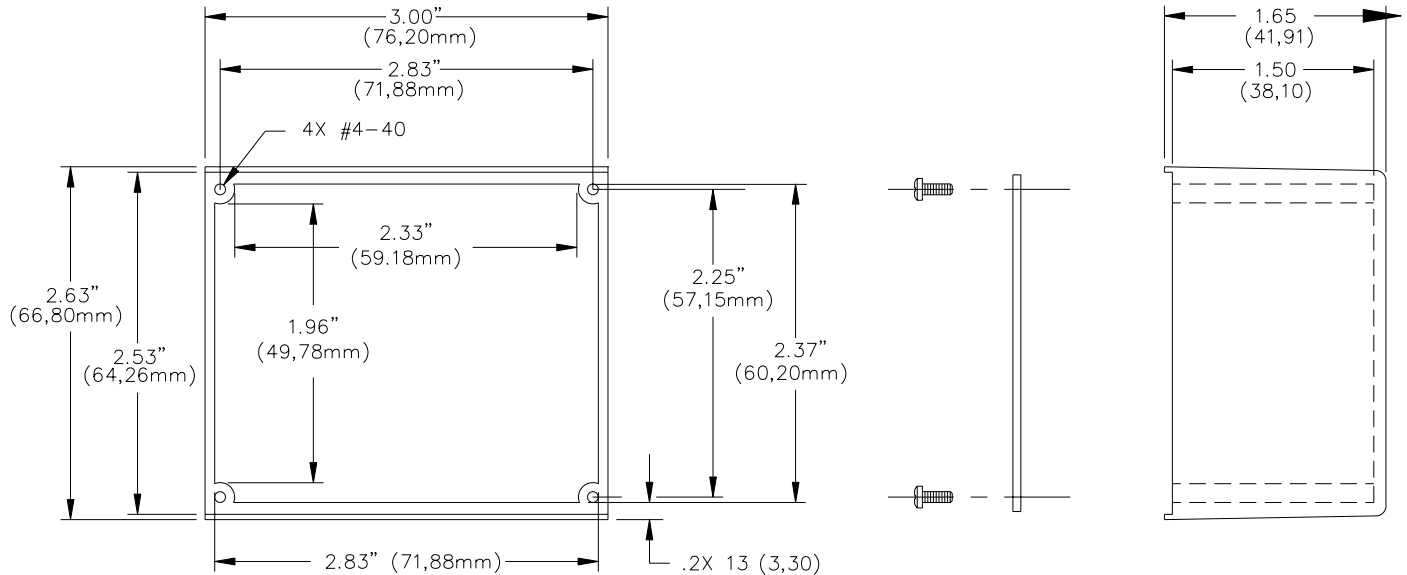

MATERIALS:

Screws: 4 each #4-40 x 6.35 (1/4") Phillips pan head pr MS 35206-213 with blue zinc plating.

Cover: 1.60 (.063) thick aluminum Alloy 1100-H14

Finish: Clear anodized per MIL-A-8625,

Shielded Housing: Die cast aluminum alloy A380 or A384.

Finish:

Model 3601: Blue baked enamel per Federal Standard 595 #25109 over primer wash per DOD-P-15328.

Model 3606: Bare die cast aluminum.



Model 3606

RATINGS:

Operating Temperature: +302°F (+150°C) Max.

ORDERING INFORMATION:

Model 3601 (Blue baked enamel)

Model 3606 (Bare die cast aluminum)

All dimensions are in inches. Tolerances (except noted): .xx = ±.02" (.51 mm), .xxx = ±.005" (.127 mm).

All specifications are to the latest revisions. Specifications are subject to change without notice.

Registered trademarks are the property of their respective companies.

Sales: 800-490-2361 Fax: 888-403-3360 Technical Support: 800-241-2060 (technicalsupport@pomonatest.com)

For "Where to Buy" information, visit the Pomona web site at www.pomonaelectronics.com