

Model 3603
Shielded Housing, Size "D"
BNC Female To BNC Male

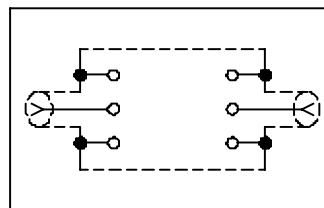
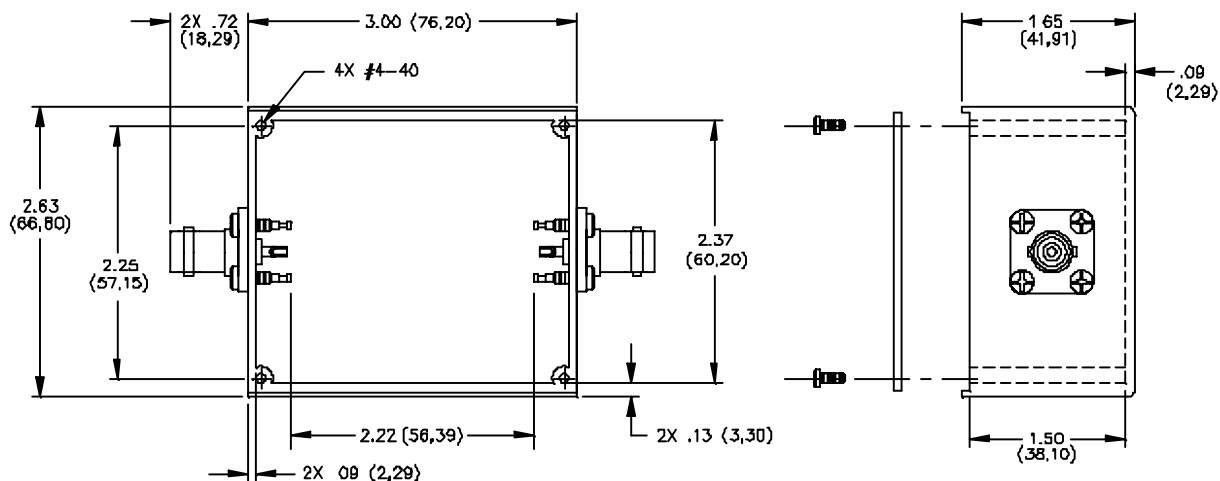

SCHEMATIC

MATERIALS:

Connector: 2 each BNC Female

Finish:

Body and Fittings – Tarnish resistant

Center Contact – Gold plated

Nominal Impedance: 50 Ohms. Solder Turret

Terminal Screws: 4 each, 4-40 pan head. Material: Steel.

Shielded Housing: Die cast aluminum Alloy A380 or A384.

Finish: Blue baked enamel per Federal Standard 595 #25109 over primer wash per DOD-P-15328.

Cover: 1.60 (.063) thick aluminum 1100-H14

Finish: Clear anodized per MIL-A-8625

Screws: 8 each, #4-40 x 6.35 (1/4) with blue zinc plating.

Connector: BNC Male

Finish:

Body & Fittings: Tarnish Resistant.

Center Contact: Gold plated

Nominal Impedance: 50 Ohms

RATINGS:

Operating Temperature: +150°C. (+302°F.) Max.

ORDERING INFORMATION: Model 3603

All dimensions are in inches. Tolerances (except noted): .xx = ±.02" (.51 mm), .xxx = ±.005" (.127 mm). All specifications are to the latest revisions. Specifications are subject to change without notice. Registered trademarks are the property of their respective companies.

Made in USA