

## Model 3777A Spade Lug to Banana Jack

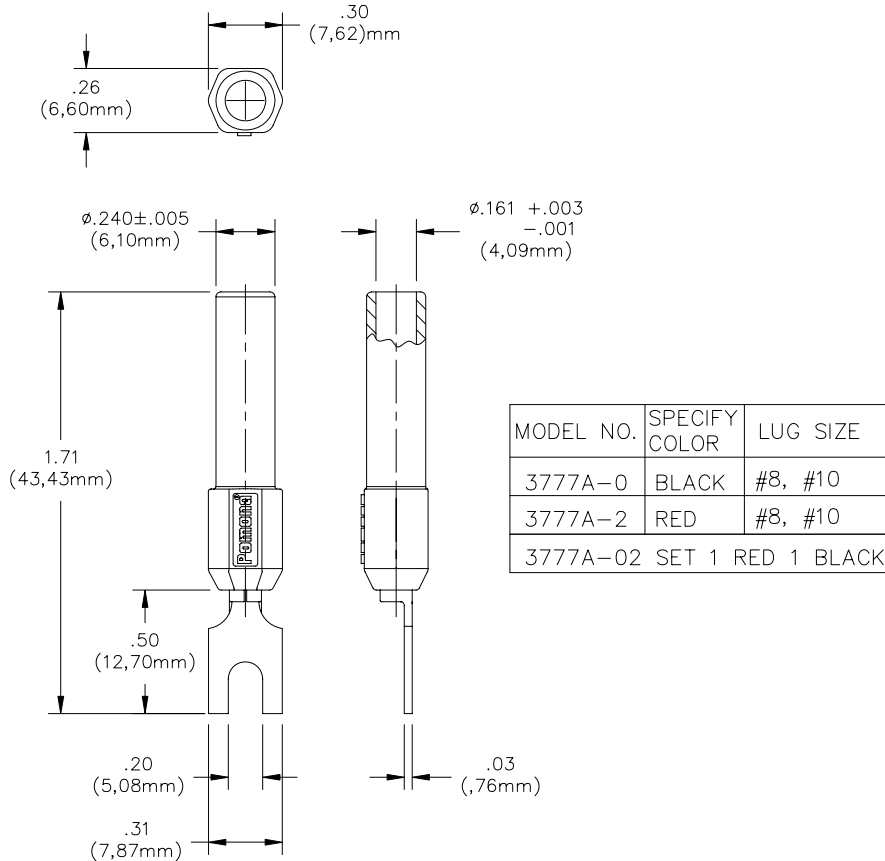

### MATERIALS:

**1<sup>st</sup> End:** Banana Jack

Material: Brass per QQ-B-626, Alloy 360, ½ Hard.

Finish: Nickel plated per Q-N-290, Class 2, 200/300 microinches.

Insulation: Polypropylene (Fire Retardant) molded to Banana Jack Body. Color: See Tab Block.

Marking: "POMONA"

**2<sup>nd</sup> End:** Spade Lug

Material: Copper.

Finish: Electro-tin plated.

### RATINGS:

Operating Temperature: +50° C (+122° F) Max.

Operating Voltage: 5000 VDC

Current: 15 Amperes

### ORDERING INFORMATION:

See table above

**USA:** Sales: 800-490-2361  
 Technical Support: [technicalsupport@pomonatest.com](mailto:technicalsupport@pomonatest.com)  
 Fax: 425-446-5844

**Europe:** 31-(0) 40 2675 150 **International:** 425-446-5500

**Where to Buy:** [www.pomonaelectronics.com](http://www.pomonaelectronics.com)

All dimensions are in inches. Tolerances (except noted): .xx = ±.02" (.51 mm), .xxx = ±.005" (.127 mm). All specifications are to the latest revisions. Specifications are subject to change without notice. Registered trademarks are the property of their respective companies.