

Model 4656
Component Housing
Five BNC Females

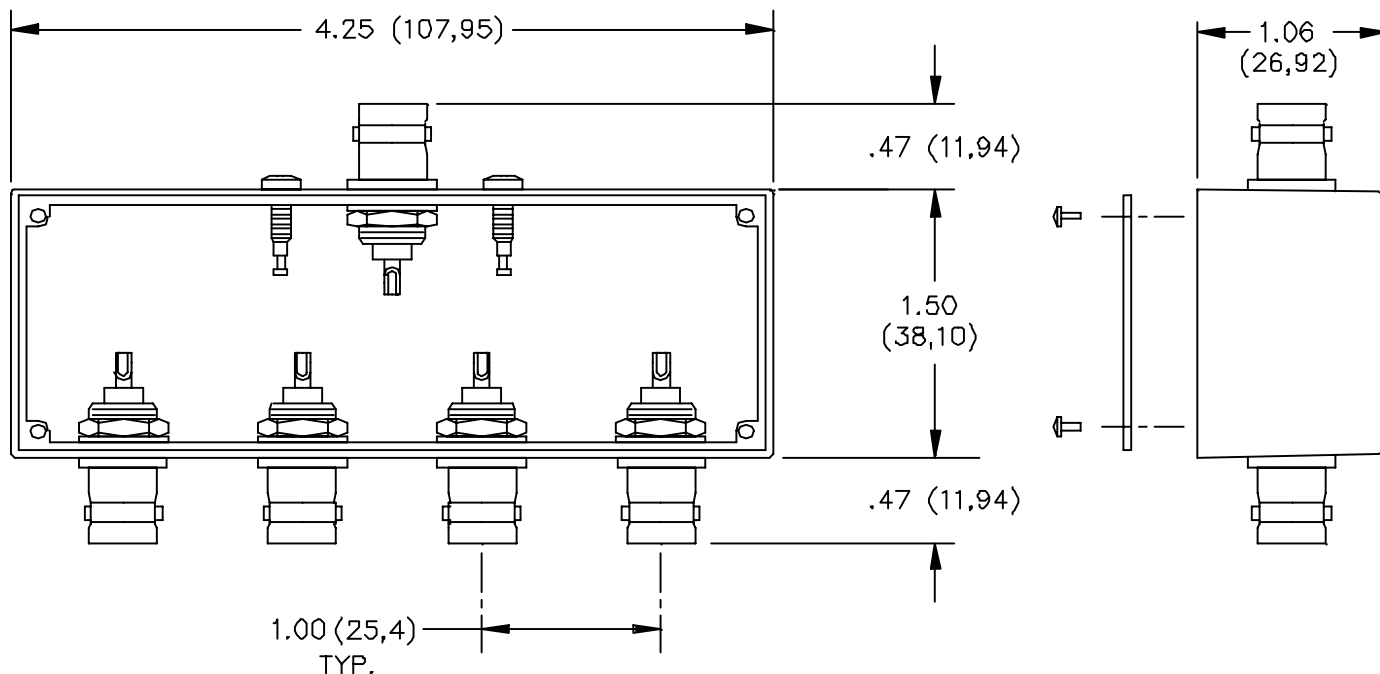

MATERIALS:

Connector: 5 ea. BNC Female.

Nominal Impedance: 50 Ohms

Finish: Tarnish Resistant

Screw/Solder Turret: 2 ea. #4-40. Steel

Housing: Die cast Aluminum, Alloy A380 or A394.

Finish: Blue paint per Federal Standard 595, #25109 over Phosphoric etch

Marking: POMONA ELECTRONICS, CALIF.

Cover: 16.0 (.063) thick Aluminum Alloy 1100-H14 pr QQ-A-250/1.

Finish: Clear Anodized

Screw: 4 ea. #2-32 x 1/4" pan head, self-tapping. Steel

RATINGS:

Operating Temperature: -55°C. to +150°C. (-67°F. to +302°F.)

ORDERING INFORMATION: Model 4656

All dimensions are in inches. Tolerances (except noted): .xx = ±.02" (.51 mm), .xxx = ±.005" (.127 mm).

All specifications are to the latest revisions. Specifications are subject to change without notice.

Registered trademarks are the property of their respective companies.

Made in USA