

Model 5090 BNC (F) to 2 Lug Triaxial (M) Adapter

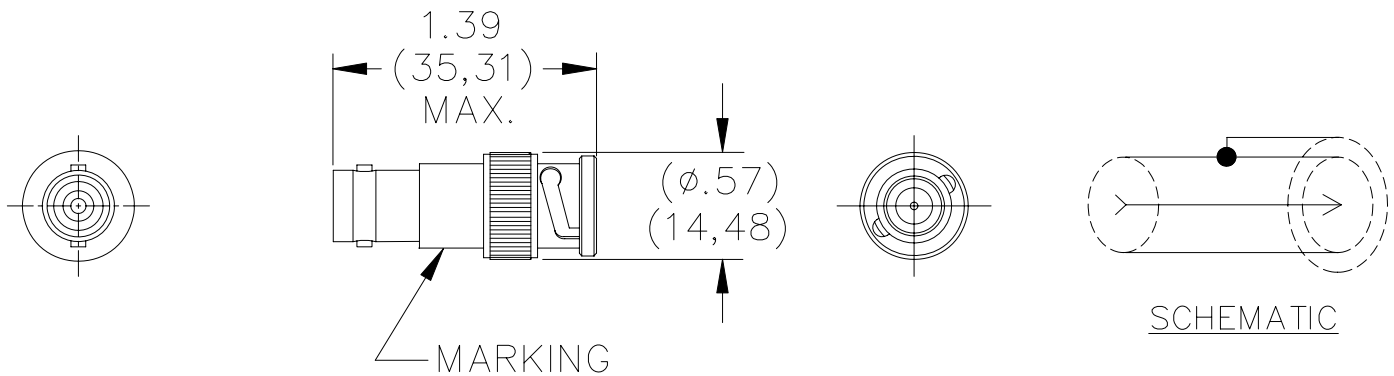

Features

- Provides an easy interface between a BNC (F) and a 2 Lug Triax (M).

Materials

Body: Brass, Tarnish Resistant Nickel Plated
Dielectric: PTFE per L-P-403
Center Contact: Male – Brass, Gold Plated
 Female – Beryllium Copper, Gold Plated
Outer Contact: Beryllium Copper, Tarnish Resistant
Marking: "POMONA 5090" (optional)



Specifications

Operating Voltage: For CE compliance: not intended for hand-held use at voltages above 33 Vrms/70 Vdc.
 Frequency Range: DC to 500 MHz

Ordering Information

Model: 5090

USA: Sales: 800-490-2361
 Technical Support: technicalsupport@pomonatest.com
 Fax: 425-446-5844
Europe: 31-(0) 40 2675 150 **International:** 425-446-5500
Where to Buy: www.pomonaelectronics.com

All dimensions are in inches. Tolerances (except noted): .xx = ±.02" (.51 mm), .xxx = ± .005" (.127 mm). All specifications are to the latest revisions. Specifications are subject to change without notice. Registered trademarks are the property of their respective companies.