

Model 5203 Die Cast Box With Card Guides Size L, Unpainted

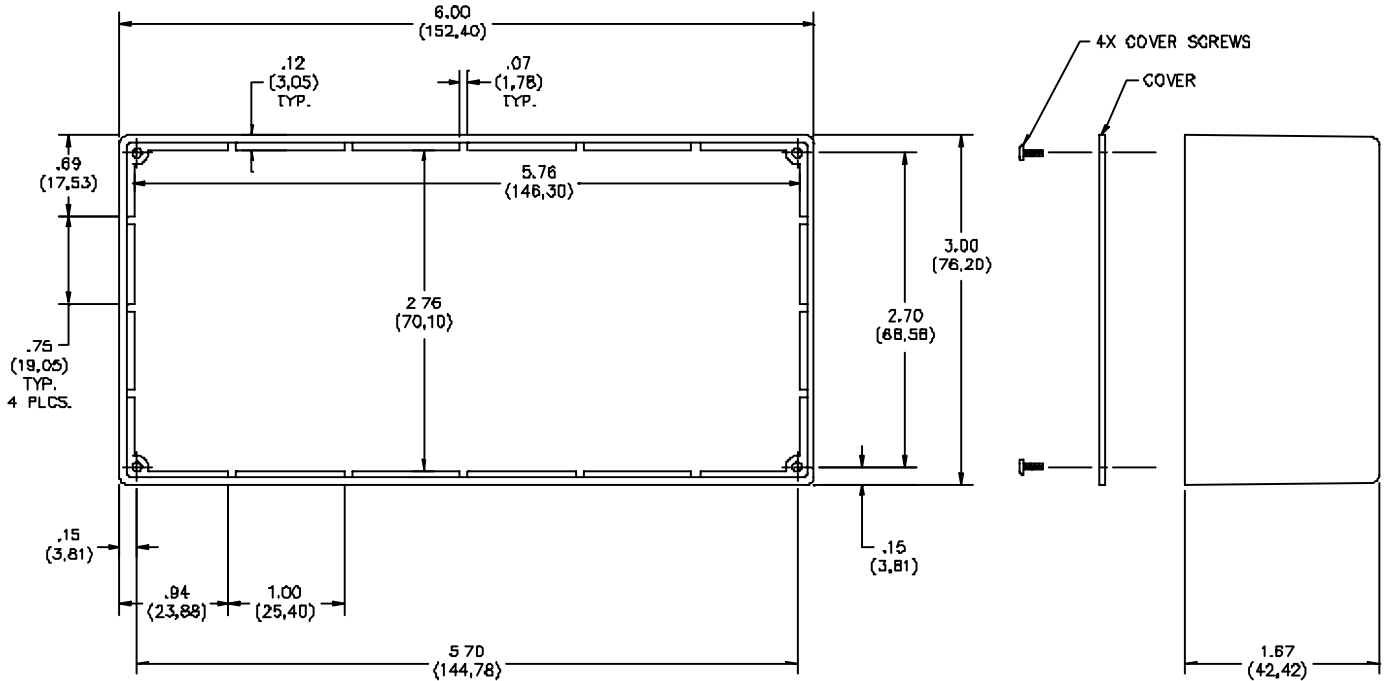

MATERIALS:

Die Cast Box:

Aluminum die cast, Alloy A380 or A384
Finish: None
Marking: "POMONA ELECTRONICS, CALIF."

Cover:

1.60 mm (.063) thick aluminum Alloy 1100-H14
Finish: Clear anodized
Marking: None

Screws:

4 each, 2-32 X 6.35 MM (.25) long Pan Head, self-tapping
Steel
Finish: Nickel Plated

RATINGS:

Operating Temperature: -55° C. to +150°C. (-67°F. to +302°F.)

ORDERING INFORMATION: Model 5203

All dimensions are in inches. Tolerances (except noted): .xx = ±.02" (.51 mm), .xxx = ±.005" (.127 mm).
All specifications are to the latest revisions. Specifications are subject to change without notice.
Registered trademarks are the property of their respective companies. Made in USA