

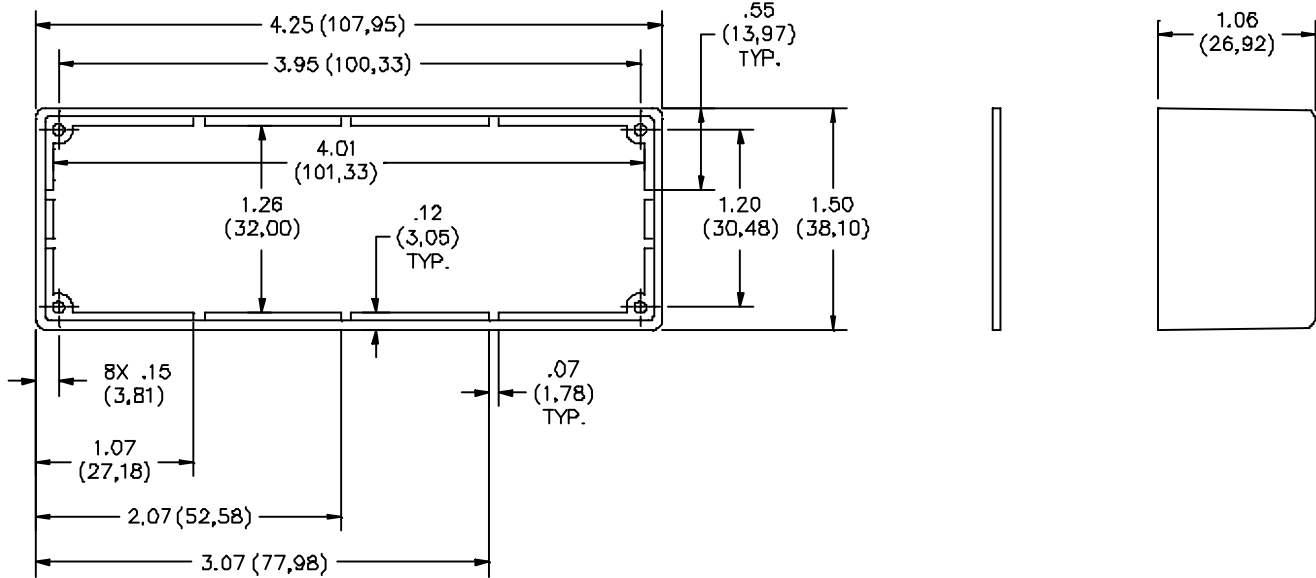

PEWA  
 Messtechnik GmbH  
 Weidenweg 21  
 58239 Schwerte  
 Tel.: 02304-96109-0  
 Fax: 02304-96109-88  
 E-Mail: info@pewa.de  
 Homepage : www.pewa.de

## Model 5255 Die Cast Box, With Card Guides Size J, Unpainted



### MATERIALS:

#### Die Cast Box:

Aluminum, die cast, Alloy 380 or A384  
 Finish: None  
 Marking: "POMONA ELECTRONICS, CALIF"

#### Cover:

1.60 (.063) thick aluminum, Alloy 1100-H14  
 Finish: Clear anodized  
 Marking: None

#### Screws:

4 each 2-32 X 6.35 (.25) long, pan head, slotted, self-tapping  
 Steel

### RATINGS:

Operating Temperature: -55°C. to +150°C. (-67°F. to +302°F.)

### ORDERING INFORMATION: Model 5255

All dimensions are in inches. Tolerances (except noted): .xx = ±.02" (.51 mm), .xxx = ±.005" (.127 mm).  
 All specifications are to the latest revisions. Specifications are subject to change without notice.  
 Registered trademarks are the property of their respective companies.

Made in USA

6/9/99  
 SY/EH/LS

Sales: 800-490-2361 Fax: 888-403-3360  
 Technical Assistance: 800-241-2060

PomonaACCESS 90325 (800) 444-6785 or (425) 446-6010  
 More drawings available at www.pomonaelectronics.com

C:\Laura Goldberg\FlukeDataSheet\d5255\_1\_01.doc

Page 1 of 1