

Model 5300 BNC (F) To Triaxial 3 Lug (M)

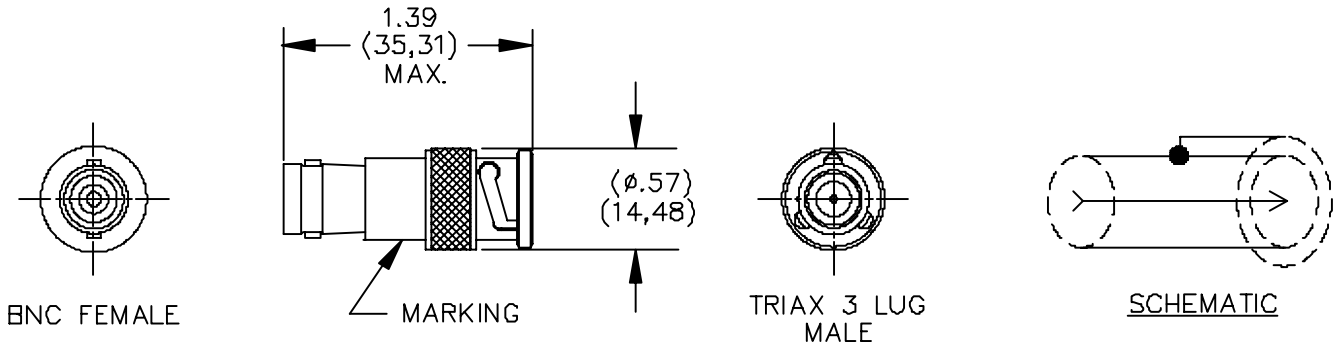

FEATURES:

- Provides an easy interface between a BNC (M) and a 3 lug triax (F)

MATERIALS:

Body and Fittings – Nickel Plated Brass, Male Contact – Gold Plated Brass, Female Contact – Gold Plated Beryllium Copper

Dielectric: Teflon per L-P-403

Finish: Body and Fittings: Tarnish resistant

Center & Intermediate Contacts: Gold Plated

Outer Contact: Tarnish resistant

Marking: “Pomona 5300”

RATINGS:

Operating Voltage: Shield/Earth: 30VAC/60VDC Max. For hands free testing in a controlled Voltage Environment: 500 VDC.

Frequency Range: DC to 500 MHz.

ORDERING INFORMATION: Model 5300

All dimensions are in inches and metric. All specifications are to the latest revisions. Specifications are subject to change without notice. Registered trademarks are the property of their respective companies. Made in USA