

## Models 72905 Clip lead for Micro SMD Grabber

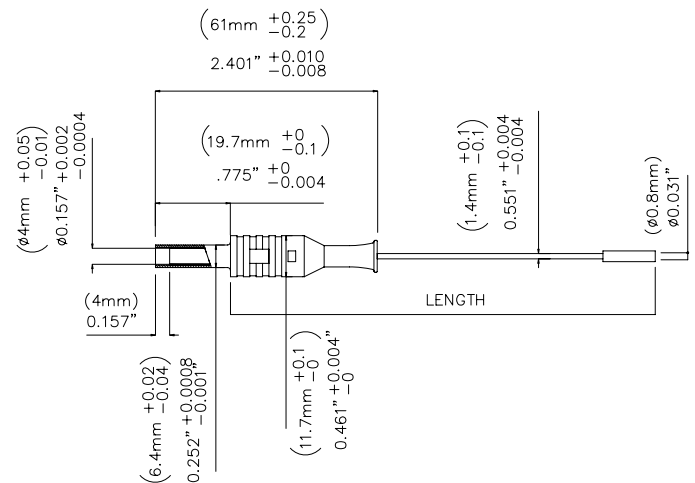

**Attach your Micro SMD  
Grabber to Standard test  
leads.**

### Features

- Clip lead for easy attachment of Micro SMD Grabbers Pomona 72902 and 72906 to standard test leads
- 0.8mm female/4mm female

### Materials

- Connector Body is Nickel plated Brass.
- Connector insulation is Polypropylene
- 0.8mm Socket is Gold over Nickel plated Brass.
- Insulation of 0.8mm is Elastomere
- Wire is Silicone.

### Ordering Information

Model: 72905-Color  
Available colors: Black (-0), Red (-2)

**USA:** Sales: 800-490-2361 Technical Support: 800-241-2060 Fax: 888-403-3360

**Europe:** 31-(0) 40 2675 150 **International:** 425-446-5500  
e-mail: [technicalsupport@pomonatest.com](mailto:technicalsupport@pomonatest.com)

**Where to Buy:** [www.pomonaelectronics.com](http://www.pomonaelectronics.com)

### Specifications

Max Current	Max. 2A
Max Voltage	33 V AC / 70 V DC
Temperature Range	-20° C + 80° C
Max Resistance	Less than 8 mΩ

**Rating:** *hands free testing* in controlled environment:  
70Vrms max. For CE compliance: Not intended for hand-held use at voltages above 33Vrms/70Vdc

All dimensions are in inches. Tolerances (except noted): .xx = ±.02" (.51 mm), .xxx = ±.005" (.127 mm). All specifications are to the latest revisions. Specifications are subject to change without notice. Registered trademarks are the property of their respective companies.