

5

4

3

2

1

DRAWING NO. 27-8120-CUST			
REVISIONS			
OFFICAL RELEASE			
01			
08-25-09	T W	B Y	T <i>Betty</i> 2009.09.0 8'09'29.19 +08'00'

Description: BNC Jack to UHF Plug Adapter
 Part No: 27-8120
 Application: Adapter
 Crimp Tool: N/A
 Impedance: 75 Ohms
 Fequency Range: 0-750M GHz
 Material: Body Brass Nickel Plated
 Contact Brass Gold Plated
 Insulator Delrin
 Crimp Sleeve Brass Nickel Plated
 Coupling Nut Zinc Nickel Plated

RoHS Compliance: Yes
 Technical Detail: Refer to Emerson Document P/N 27-0000&29-0000



受控 CONTROLLED DOCUMENT					
编号 P/N	27-8120-C U ST	版本 Rev	01	日期 Rel'd Date	SEP 14,09

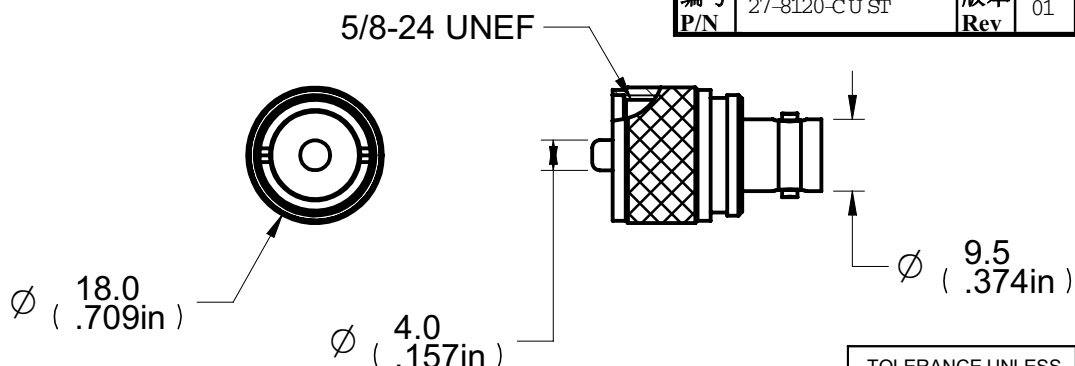

TOLERANCE UNLESS OTHERWISE SPECIFIED		DRAWN BY TERRY.W	DATE 08-25-09
DECIMALS	mm	CHECKED BY TERRY.W	DATE 08-25-09
X	± 0.5	APPROVED BY	DATE
X.X	± 0.3	THOMAS	08-25-09
X.XX	± 0.1	U/M	mm
ANGLES	± 0.5°		

PEWA Messtechnik GmbH
 Weidenweg 21
 58239 Schwerte
 Tel.: 02304-96109-0
 Fax: 02304-96109-88
 E-Mail: info@pewa.de
 Homepage : www.pewa.de

K&S Elektronik **MB-electronic**

BNC JACK TO UHF PLUG ADAPTER

DIM OUTLINE

THIS DRAWING WAS PRODUCED BY COMPUTER, DO NOT SCALE DRAWING OR UPDATE MANUALLY.		
SHEET 1 OF 1	DRAWING NO. 27-8120-CUST	SIZE A

5

4

3

2

1