

DRANFLEX 3000XL and 6000XL CURRENT PROBES



WARNING

Death, serious injury, or fire hazard could result from improper connection of this instrument. Read and understand these instructions and the Operator's Manual before connecting this instrument. Follow all installation and operating instructions while using this instrument.

Connection of this instrument must be performed in compliance with the National Electrical Code (ANSI/NFPA 70-2008) of USA and any additional safety requirements applicable to your installation.

Installation, operation and maintenance of this instrument must be performed by qualified personnel only. The National Electrical Code defines a qualified person as "one who has the skills and knowledge related to the construction and operation of the electrical equipment and installations, and who has received safety training on the hazards involved."

Qualified personnel that work on or near exposed energized electrical conductors must follow applicable safety related work practices and procedures including appropriate personal protective equipment in compliance with the Standard for Electrical Safety Requirements for Employee Workplaces (ANSI/NFPA 70E-2004) of USA and any additional workplace safety requirements applicable to your installation.

ADVERTENCIA

Una conexión incorrecta de este instrumento puede producir la muerte, lesiones graves y riesgo de incendio. Lea y entienda este manual antes de conectar. Observe todas las instrucciones de instalación y operación durante el uso de este instrumento.

La conexión de este instrumento debe ser hecha de acuerdo con las normas del Código Eléctrico Nacional (ANSI/NFPA 70-2008) de EE. UU., además de cualquier otra norma de seguridad correspondiente a su establecimiento.

La instalación, operación y mantenimiento de este instrumento debe ser realizada por personal calificado solamente. El Código Eléctrico Nacional define a una persona calificada como "una que esté familiarizada con la construcción y operación del equipo y con los riesgos involucrados."

AVERTISSEMENT

Si l'instrument est mal connecté, la mort, des blessures graves, ou un danger d'incendie peuvent s'en suivre. Lisez attentivement ce manuel avant de connecter l'instrument. Lorsque vous utilisez l'instrument, suivez toutes les instructions d'installation et de service.

Cet instrument doit être connecté conformément au National Electrical Code (ANSI/NFPA 70-2008) des Etats-Unis et à toutes les exigences de sécurité applicables à votre installation.

Cet instrument doit être installé, utilisé et entretenu uniquement par un personnel qualifié. Selon le National Electrical Code, une personne est qualifiée si "elle connaît bien la construction et l'utilisation de l'équipement, ainsi que les dangers que cela implique."

WARNUNG

Der falsche Anschluss dieses Gerätes kann Tod, schwere Verletzungen oder Feuer verursachen. Bevor Sie dieses Instrument anschliessen, müssen Sie die Anleitung lesen und verstanden haben. Bei der Verwendung dieses Instruments müssen alle Installation- und Betriebsanweisungen beachtet werden.

Der Anschluss dieses Instruments muss in Übereinstimmung mit den nationalen Bestimmungen für Elektrizität (ANSI/NFPA 70-2008) der Vereinigten Staaten, sowie allen weiteren, in Ihrem Fall anwendbaren Sicherheitsbestimmungen, vorgenommen werden.

Installation, Betrieb und Wartung dieses Instruments dürfen nur von Fachpersonal durchgeführt werden. In den nationalen Bestimmungen für Elektrizität wird ein Fachmann als eine Person bezeichnet, welche "mit der Bauweise und dem Betrieb des Gerätes sowie den dazugehörigen Gefahren vertraut ist."

Safety Precautions

The following safety precautions must be followed whenever any type of connection is being made to the instrument.

- Connect the green safety (earth) ground first, before making any other connections.
- When connecting to electric circuits or pulse initiating equipment, open their related breakers. DO NOT install any connection of the instrument on live power lines.
- Connections must be made to the instrument first, then connect to the circuit to be monitored.
- Wear safety glasses and insulated gloves when making connections to power circuits.
- Hands, shoes and floor must be dry when making any connection to a power line.
- Make sure the unit is turned OFF before connecting probes to the rear panel.
- Before each use, inspect all cables for breaks or cracks in the insulation. Replace immediately if defective.
- If the equipment is used in a manner not specified in this user's guide, the protection provided by the equipment may be impaired.

Medidas de seguridad

Las medidas de seguridad siguientes deberán observarse cuando se realice cualquier tipo de conexión al instrumento.

- Antes de hacer cualquier conexión, deberá enchufarse el conector de seguridad verde a tierra.
- Cuando se haga conexiones a circuitos eléctricos o a equipo de activación por pulso, deberá abrirse sus respectivas cajas de seguridad. NO deberá hacerse ninguna conexión del instrumento en líneas eléctricas bajo tensión.
- Las conexiones deberán hacerse primero al instrumento y, luego, al circuito a ser monitorizado.
- Al hacer conexiones a circuitos eléctricos, deberá utilizar anteojos y guantes protectores.
- Sus manos, zapatos y el piso deberán estar secos en todo momento en que se haga una conexión a un cable eléctrico.
- Verifique que la unidad esté DESACTIVADA antes de conectar sondas en el panel posterior.
- Previo a cada uso, deberá verificarse que los cables no estén rotos y que el material aislante no tenga rajaduras. Reemplace de inmediato cualquier parte defectuosa.

Mesures de Sécurité

Les mesures de sécurité suivantes doivent être prises chaque fois qu'un type de connexion quelconque est effectué sur l'instrument.

- o Connecter d'abord la prise de terre de sécurité verte (terre) avant d'effectuer toute autre connexion.
- o Ouvrir les disjoncteurs correspondants lors d'une connexion à des circuits électriques ou à des équipement de génération d'impulsions. NE PAS effectuer de connexion d'instrument sur des lignes électriques sous tension.
- o Une fois toutes les connexions de l'instrument effectuées, connecter au circuit à contrôler.
- o Porter des lunettes de protection et des gants isolants pour effectuer des connexions aux circuits électriques.
- o S'assurer que les mains, les chaussures et le sol soient secs lors de connexions à une ligne électrique.
- o S'assurer que l'unité est ÉTEINTE avant de connecter les sondes au panneau arrière.
- o Inspecter tous les câbles, avant chaque utilisation, pour s'assurer que les isolants ne sont pas coupés ou fendus. Remplacer immédiatement tous les équipements défectueux.

Sicherheitsvorkehrungen

Die folgenden Sicherheitsvorkehrungen sind immer dann zu befolgen, wenn eine Verbindung zum Instrument hergestellt wird.

- o Schließen Sie zuerst die grüne Sicherheits-/Erdleitung an, bevor Sie eine andere Verbindung herstellen.
- o Öffnen Sie beim Anschluß an elektrische Stromkreise oder Impulsauslösungseinrichtungen die entsprechenden Unterbrecher. Es dürfen KEINE Anschlüsse an das Instrument unter stromführenden Spannungsleitungen montiert werden.
- o Die Verbindungen müssen zuerst am Instrument und danach an der zu überwachenden Schaltung hergestellt werden.
- o Tragen Sie Schutzbrillen und Isolierhandschuhe, wenn Sie Anschlüsse an den Stromkreisen vornehmen.
- o Hände, Schuhe und Fußboden müssen trocken sein, wenn Sie Anschlüsse an den Stromkreisen durchführen.
- o Stellen Sie sicher, daß das Gerät AUSgeschaltet ist, bevor Sie an der rückwärtigen Konsole Meßfühler anschließen.
- o Prüfen Sie vor jedem Gebrauch alle Kabel auf Bruchstellen und Risse in der Isolierung. Wechseln Sie schadhafte Kabel sofort aus.

INTRODUCTION

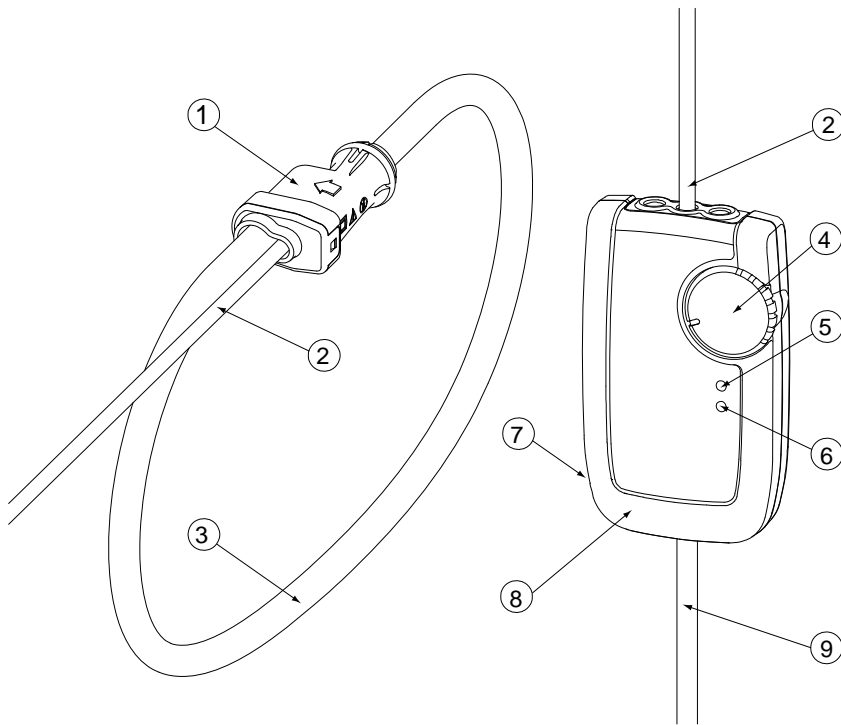

FIG 1

1. Probe Coupling
2. Probe Output Cable
3. Flexible Current Probe
4. Power On / Range Switch
5. RED LED – Overload
6. ORANGE LED – Low Battery
7. External Power Supply Input
8. Integrator Housing
9. Output Cable

These optional current probes allow current measurements in the range of 0.5 Amps to 3000A full scale or 0.5 Amps to 6000A full scale for use with the PX5, 4400, Signature System DataNode with TRTO55 cable adapter (DB P/N 116817-G1), and Encore Series 61000 System with TRTO55 cable adapter or 61MAC current probe module.

There are several current probe models available as follows.

- **30 / 300 / 3000A**
 - DRANFLEX 3000XL/24 24 inch length
 - DRANFLEX 3000XL/36 36 inch length
 - DRANFLEX 3000XL/48 48 inch length

- **60 / 600 / 6000A**
 - DRANFLEX 6000XL/24 24 inch length
 - DRANFLEX 6000XL/36 36 inch length
 - DRANFLEX 6000XL/48 48 inch length

SPECIFICATIONS

- Accuracy at 50 to 60Hz:

<i>Amplitude</i>	<i>10%-100% of full scale of probe range</i>
30 / 300 A Range	±1% of reading ± 0.1A
3000 A Range	±1% of reading ± 1A
60 / 600 A Range	±1% of reading ± 0.1A
6000 A Range	±1% of reading ± 1A

Note: Overall measurement accuracy is the probe accuracy plus the instrument accuracy. Refer to the applicable Dranetz-BMI instrument User's guide for measurement accuracy for the instrument you are using.

Phase (45 – 65Hz) ±1 degree

- Rated Voltage 1000 V Maximum
- Output Signal

Ranges 30 / 300 or 3000A	1.5VRMS
Ranges 60 / 600 or 6000A	1.5VRMS
- Frequency Range 10 to 10kHz (-3dB)
- Maximum Conductor Size
 - 24 inch probe length conductor(s) up to 8 inch diameter
 - 36 inch probe length conductor(s) up to 11 inch diameter
 - 48 inch probe length conductor(s) up to 17 inch diameter
- Environmental
 - Operating Temperature*
 - 20°C to + 80°C
 - 0-90% Relative Humidity (non-condensing)
 - Storage Temperature*
 - 40°C to + 90°C
 - Altitude* 2000m (6560ft) maximum
 - Installation Category* III, Pollution Degree 2
- Power Supply
 - 2 x AA MN1500 LR6 Alkaline Batteries, (2000 hours of continuous operation).
 - OR External power supply (3V/100mA)
- Safety Standards
 - EN 61010-1:2001
 - EN 61010-031:2002
 - EN 61010-2-032:2002

30V maximum between Output and Earth

CONNECTION PROCEDURE

WARNING

To reduce the risk of fire, electrical shock, or physical injury it is strongly recommended to make connections to the instrument with all circuits de-energized. If it is necessary to make connections on energized circuits they must be made by Qualified personnel ONLY.

The National Electrical Code defines a qualified person as “one who has the skills and knowledge related to the construction and operation of the electrical equipment and installations, and who has received safety training on the hazards involved.”

Qualified personnel that work on or near exposed energized electrical conductors must follow applicable safety related work practices and procedures including appropriate personal protective equipment in compliance with the Standard for Electrical Safety Requirements for Employee Workplaces (ANSI/NFPA 70E-2004) of USA and any additional workplace safety requirements applicable to your installation.

Always refer to the applicable User’s Guide for additional information concerning installation, operation, and connections of Dranetz-BMI or Original Equipment Manufacturer’s instructions applicable to your installation.

1. With all power “OFF” connect the probe end to your instrument and then connect the probe around the conductors that you will be monitoring. Make sure that the flexible probe and the connector at the unit are fully secured and mated properly.
2. Turn power “ON” to the unit and measurement circuits.
3. Select the desired range on the current probe.
4. Refer to the scale factor tables and enter the scale factor for the appropriate channel for the applicable instrument you are using.
5. Refer to the Dranetz-BMI User’s Guide for additional information concerning installation, operation, and connections of your instrument.



Do not use the flexible current probe to measure on bare conductors unless wearing protective clothing suitable for high voltage work.

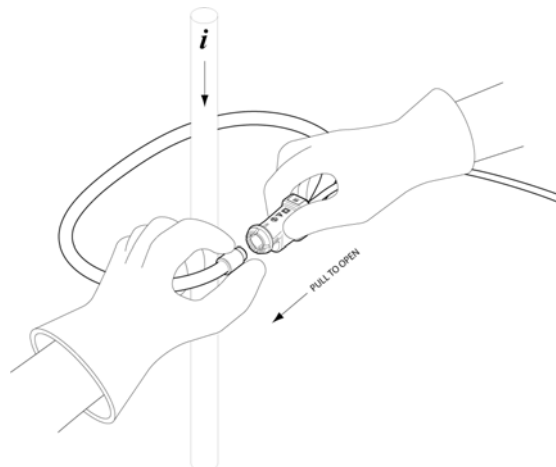

EXTERNAL SUPPLY

The current probe is packaged with 2 x AA MN 1500 1.5V batteries installed and will operate on battery power typically for approximately 2000 hours of continuous operation.

For longer monitoring periods it is possible to power one or up to four DRANFLEX XL probes from an external 3 VDC (100 mA) supply. The DC input jack on the side of the probe enclosure accommodates a 2.1 x 5.5 mm barrel connector using the center pin as the negative terminal and the outside barrel connection as the positive terminal.

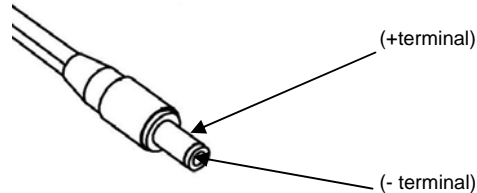

CAUTION

The current probe will not operate properly if the correct polarity is not properly connected when using an external supply.

A recommended 3VDC supply is available in three models and can be used with PX5, 4400, Signature System DataNode, or Encore Series 61000. The model numbers are RR/PSUS (US version), RR/PSEU (Euro version), and RR/PSUK (UK version). An alternate 3VDC accessory is available for use only with the PX5 and 4400 the model number is ADPPX5-FLEX3V. Also, an adapter cable RR/4P is available that will allow connection of up to four DRANFLEX XL probes that can be powered from a single power source.

To order accessories, contact Dranetz-BMI Customer Service Department at:

Dranetz-BMI	Tel: (732) 287-3680
1000 New Durham Road	Tel: 1-800-372-6832
Edison, NJ 08818-4019 USA	Fax: (732) 248-1834
Attention: Customer Service	www.dranetz-bmi.com

SCALE FACTORS

The following scale factors are used when using DRANFLEX 3000XL probes with either a PX5, or 4400.

PROBE	RANGE	SCALE FACTORS
DRANFLEX 3000XL 3000A	30 A	20
	300 A	200
	3000 A	2000
DRANFLEX 6000XL 6000A	60 A	40
	600 A	400
	6000 A	4000

The following scale factors are used when using DRANFLEX XL probes with a Signature System DataNode with TRTO55 cable adapter or Encore Series 61000 with either TRTO55 or 61MAC module.

PROBE	RANGE	SCALE FACTORS	
		Primary	Secondary
DRANFLEX 3000XL 3000A	30 A	20	1
	300 A	200	1
	3000 A	2000	1
DRANFLEX 6000XL 6000A	60 A	40	1
	600 A	400	1
	6000 A	4000	1

MEASURING LOW LEVEL CURRENTS

When measuring Neutral currents or levels at the low end of the probe ratings you can increase the accuracy and sensitivity by placing the flexible probe end around the conductor(s) twice. When utilizing the probe in this manner, you must also divide the scale factors by two (2). For example: 300A Scale Factor of 200 would translate to a Scale Factor of 100.

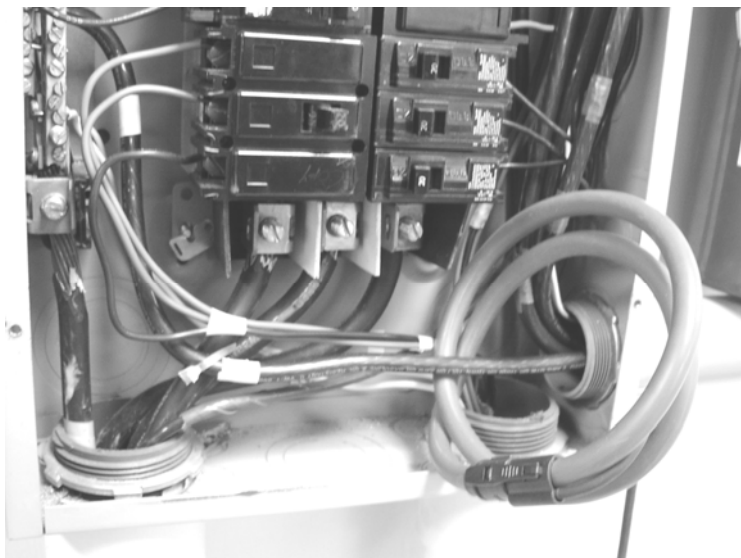

BATTERY STATUS

Battery status is indicated by an orange LED on the front of the integrator module. This LED will flash one time when the unit is switched ON. The length of time the LED is lit will increase as battery life decreases. Continuous lighting of LED indicates low battery and requires batteries to be replaced.

BATTERY REPLACEMENT

Should you suspect a depleted battery or the low battery LED blinking, proceed as follows.

1. Turn "OFF" all power to the unit and measurement circuits.
2. Set the probe selector switch to the "OFF" position.
3. Remove the flexible current probe from around the conductor wires of your measurement circuit.
4. Disconnect the flexible probe at the applicable Dranetz-BMI instrument.
5. Rotate the battery lock screw (1/4 turn) until it aligns with the unlock symbol. The battery cover can now be removed.
6. Remove the batteries from the battery holder.
7. Install the replacement batteries into the battery holder.
8. Replace the battery cover and turn the battery lock until it aligns with the lock symbol.
9. With all power "OFF" to the unit and measurement circuits connect the probe end to the applicable Dranetz-BMI unit. Next, position the flexible current probe around the conductor wires of your measurement circuit and connect the probe ends until they mate securely.
10. Refer to the applicable Dranetz-BMI User's Guide for additional information concerning installation, operation, and connections of your instrument.



WARNING

Make sure all connections are properly connected before power is applied to the measurement circuits. Failure to do so could result in risk of fire, electrical shock, or physical injury.

11. Power "ON" the unit and then turn power "ON" to the measurement circuits and you can now return to normal operation.

Statement of warranty

All products of Dranetz-BMI are warranted to the original purchaser against defective material and workmanship for a period of one year from the date of delivery. Dranetz-BMI will repair or replace, at its option, all defective equipment that is returned, freight prepaid, during the warranty period. There will be no charge for repair provided there is no evidence that the equipment has been mishandled or abused. This warranty shall not apply to any defects resulting from improper or inadequate maintenance, buyer-supplied hardware/software interfacing, unauthorized modification or misuse of the equipment, operation outside of environmental specifications, or improper site preparation or maintenance.

Statement of reliability

The information in this manual has been reviewed and is believed to be entirely reliable, however, no responsibility is assumed for any inaccuracies. All material is for informational purposes only and is subject to change without prior notice.

Notice regarding proprietary rights

This publication contains information proprietary to Dranetz-BMI. By accepting and using this manual, you agree that the information contained herein will be used solely for the purpose of operating equipment of Dranetz-BMI.

Copyright

This publication is protected under the Copyright laws of the United States, Title 17 et seq. No part of this publication may be reproduced, transmitted, transcribed, stored in a retrieval system, or translated into any language or computer language, in any form, by any means, electronic, mechanical, magnetic, optical, chemical, manual, or otherwise, without the prior written consent of Dranetz-BMI, 1000 New Durham Road, Edison, New Jersey 08818.

Copyright © 2008 Dranetz-BMI

All Rights Reserved. Printed in the United States of America.

Trademarks

DataNode[®] and Encore[®] are registered trademarks of Dranetz-BMI.

SAFETY

The following symbols appear on the product



Double/Reinforced Insulation



Attention! Refer to Manual



Do not apply around or remove from HAZARDOUS LIVE conductors without additional protective means. "Additional protective means" can be de-energizing the circuit or wearing protective clothing suitable for high voltage work.



Complies with the relevant European standards



Do not dispose of this product as unsorted municipal waste. Contact a qualified recycler for disposal.

12/08/2008
