

# Instruction Manual

## HI 3886/O pH 7.5-10.0 Test Kit

### Specifications

Range	7.5-10.0 as pH unit
Smallest Increment	0.5 as pH unit
Analysis Method	Colorimetric
Sample Size	5 mL
Number of Tests	100
Case Dimensions	115x102x82 mm (4.5x4.0x3.2")
Shipping Weight	150 g (5.3 oz.)

### Significance and Use

pH represents acidity or alkalinity of an aqueous solution and is proportional to the hydrogen-ion concentration of the solution. Under neutral conditions water is dissociated into the OH<sup>-</sup> and H<sup>+</sup> ions in equal ratio and hence it has a pH of 7. When bases or acids are added to a water solution they ionize, increasing the concentration of OH<sup>-</sup> or H<sup>+</sup>, respectively. Thus solutions with a pH of 1-3 contain strong acids, whereas those with a pH of 4-6 contain weak acids. Weak bases result in solutions of pH 8-10 and strong bases in pH of 11-13.

Examples of pH value for some liquids:

Liquid	pH Value
sea water	7.8-8.2
gastric juices	1.7
milk	6.5-7
soil	6-7 (optimum for crops)

### Chemical Reaction

HI 3886-0 Hanna Reagent reacts in contact with the aqueous solution changing its color according to the hydrogen-ion concentration (pH) in the given range.

### Instructions

READ THE ENTIRE INSTRUCTIONS BEFORE USING THE KIT

- **Note:** always shake the HI 3886-0 reagent bottle before use.

- Fill the color comparator cube with 5 mL of the sample.



- In case of concentration of chlorine above 50 ppm, add one drop of the **Dechlorinating Reagent** to the sample. Replace the cap and mix by inverting the cube several times.

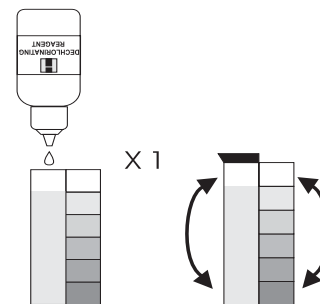

- Determine which color best matches the solution in the cube and record the result as pH unit.



- It is better to match the color with a white sheet at about 10 cm behind the color comparator cube.

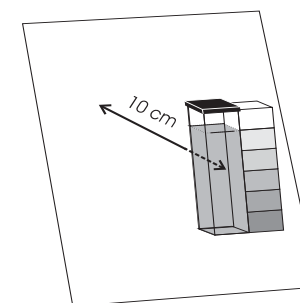

**Note:** To measure pH in the 4.0-6.5 range use the HI 3880 pH 4.0-6.5 Test Kit.

To measure pH in the 6.0-8.5 range use the HI 3881 pH 6.0-8.5 Test Kit.

### Accessories

HI 3886-010 replacement reagent kit (100 tests)

### Referencies

Vogel's  
Quantitative Chemical Analysis  
5th Ed.  
Longman Scientific & Technical.

### Safety Data Sheets

The chemicals contained in this kit may be hazardous if improperly handled. Read the relevant Safety Data Sheet before performing this test.

  
**PEWA**  
Messtechnik GmbH  
Weidenweg 21  
58239 Schwerte  
Tel.: 02304-96109-0  
Fax: 02304-96109-88  
E-Mail: info@pewa.de  
Homepage: www.pewa.de

  
**K&S**  
Elektronik **MB-electronic**

Dear Customer,

Thank you for choosing a Hanna Product.

Please read the instructions carefully before using the chemical test kit. It will provide you with the necessary information for a correct use of the kit.

Remove the chemical test kit from the packing material and examine it carefully to make sure that no damage has occurred during shipping. If there is any noticeable damage, notify your Dealer or the nearest Hanna office immediately.

Each kit is supplied with:

- HI 3886-0 pH 7.5-10.0 Reagent, 1 bottle with dropper (25 mL);
- Dechlorinating Reagent, 1 bottle with dropper (10 mL), to be used in presence of chlorine above 50 ppm;
- 1 color comparator cube.

**Note:** Any damaged or defective item must be returned in its original packing materials.