



Photovoltaics in Buildings

Guide to the installation
of PV systems
2nd Edition



PEWA
Messtechnik GmbH

Weidenweg 21
58239 Schwerte

Tel.: 02304-96109-0
Fax: 02304-96109-88
E-Mail: info@pewa.de
Homepage : www.pewa.de



dti

the department for Enterprise

DTI/Pub URN 06/1972

Preface to 2nd edition 2006

Since the first edition (2002) the guide has been updated to reflect the significant experience gained within the UK PV industry under the DTI solar PV grants programmes. Other major changes covered include:

- 1 Engineering Recommendation G83/1(2003) issued to replace ER G77/1
- 1 additional guidance for off-grid battery systems
- 1 guidance for larger systems connected under ER G59/1
- 1 Part P Building Control notification Requirements

ETSU Report No:

ETSU S/P2/00355/REP/1

Authors

BRE
EA Technology
Halcrow Group
SunDog Energy
(2nd Edition: Sundog Energy, Halcrow Group,
Energy Saving Trust)

Acknowledgments

Thanks to the following for commenting on the drafts
IEE, HSE, ESD, Intersolar, NAPS Systems, NHBC, Dulas,
CREST, DTI Engineering Inspectorate, EST, Solarcentury.
Special thanks to Martin Cotterell

First Published

2002

2nd Edition

2006

The work described in this report was carried out under contract as part of the DTI Sustainable Energy Programmes. The views and judgements expressed in this report are those of the contractor and do not necessarily reflect those of the DTI. This guide was originally prepared by BRE and others on behalf of the DTI. Every effort has been made to ensure that the information given herein is accurate but no legal responsibility can be accepted by the DTI, BRE and their collaborators, for any errors, omissions or misleading statements.

1.0 INTRODUCTION	5
1.1 Scope	5
1.2 Standards and regulations	5
1.3 Safety	5
1.4 Parallel generation	6
1.5 Note on layout	7
1.6 Ready reference to the guide	8
1.7 List of terms	8
2.0 DESIGN	10
2.1 Design part 1 – d.c. system	10
2.1.1 PV modules	10
2.1.1.1 Standard modules	10
2.1.1.2 Building integrated products/modules	10
2.1.2 d.c. system - minimum voltage and current ratings	10
2.1.3 PV array design	11
2.1.4 d.c. cables – general	12
2.1.4.1 Cable sizing	12
2.1.4.2 Cable type and installation method	12
2.1.5 String cables	13
2.1.6 Main d.c. cable	15
2.1.7 d.c. plug and socket connectors	15
2.1.8 Other inline cable junctions	16
2.1.9 d.c. Junction box	16
2.1.10 String fuses	17
2.1.11 Blocking diodes	18
2.1.12 d.c. switch	19
2.2 Design part 2 – earthing and lightning protection	20
2.2.1 Earthing of exposed conductive parts (array frame)	20
2.2.2 System earthing (d.c. conductor earthing)	22
2.2.3 Inverter earthing	22
2.2.4 Lightning and surge protection	22
2.2.5 Lightning protection systems	22
2.2.6 Surge protection measures	23
2.3 Design part 3 – a.c. system	24
2.3.1 a.c. cabling	24
2.3.2 a.c. switch-disconnector	25
2.3.3 Inverters	25
2.3.4 a.c. fault current protection	26
2.3.5 Metering	26

2.4 Design part 4 – design approval	26
2.4.1 DNO approval	26
2.4.2 Planning permission	27
2.4.3 Building Regulations - part P (electrical safety)	27
2.5 Battery systems	28
2.5.1 PV array charge controller	29
2.5.2 Battery overcurrent protection	29
2.5.3 Battery disconnection	29
2.5.4 Cables in battery systems	30
2.5.5 PV String cable and fuse ratings	30
2.5.6 Battery selection and sizing	30
2.5.7 Battery installation/labelling	31
2.6 System performance	32
2.6.1 Inverter sizing	30
2.6.2 System performance	33
3.0 INSTALLATION/SITWORK	35
3.1 General	35
3.2 PV specific hazards	35
3.3 d.c. circuits - installation	36
3.3.1 Personnel	36
3.3.2 Sequence of works	36
3.3.3 Live working	37
3.3.4 Shock hazard (safe working practices)	37
4.0 SYSTEM INSPECTION, TESTING & COMMISSIONING REQUIREMENTS, DOCUMENTATION & LABELLING	39
4.1 Inspection and testing	39
4.2 Array commissioning tests	39
4.3 E.R. G83/1 and G59/1 commissioning	39
4.4 Labelling	40
4.5 Operational & maintenance manual	42
Appendix A G83/1 installation commissioning confirmation form	43
Appendix B Electrical Installation certificate	45
Appendix C PV commissioning test sheets	47
Further reading	51

GUIDE TO THE INSTALLATION OF PV SYSTEMS

1.0 INTRODUCTION

1.1 Scope

The scope of this document is to supply system installers with information to ensure that a mains-connected PV system meets current UK standards and best practice recommendations. It is primarily aimed at small-scale installations (less than 16A per phase, as per the scope of ER G83/1).

The scope has been extended in this 2nd edition to provide some guidance on larger systems and off-grid battery installations.

Mechanical design of the PV array is not within the scope of this document. BRE digest 489 'Wind loads on roof-based Photovoltaic systems', and BRE Digest 495 'Mechanical Installation of roof-mounted Photovoltaic systems', give guidance in this area.

1.2 Standards and Regulations

Any PV system must comply with Health and Safety Requirements, BS 7671, and other relevant standards and Codes of Practice. Much of the content of this guide is drawn from such requirements. While many UK standards apply in general terms, at the time of writing there is still relatively little which specifically relates to a PV installation. However, there are two documents which specifically relate to the installation of these systems that are of particular relevance:

- Engineering Recommendation G83/1 (2003) – Recommendations for the connection of small scale embedded generators (up to 16A per phase) in parallel with public low voltage distribution networks
- IEE Guidance Note 7 to BS 7671 - Special Locations, Section 12 Solar Photovoltaic (PV) Power Supply Systems (ISBN 0 85296 995 3, 2003)

1.3 Safety

From the outset, the designer and installer of a PV system must consider the potential hazards carefully, and systematically devise methods to minimise the risks. This will include both mitigating potential hazards present during and after the installation phase.

The long-term safety of the system can be achieved only by ensuring that the system and components are correctly designed and specified from the outset, followed by correct installation, operation and maintenance of the system.

Consideration of operation under both normal and fault conditions is essential in the design stage to ensure the required level of safety. This aspect is covered in the DESIGN section of this guide.

It is then important to ensure that the long-term safety of the system is not compromised by a poor installation or subsequent poor maintenance. Much of this comes down to the quality of the installation and system inspection and testing regime. This is covered in the INSTALLATION section of this guide.

Similarly, much can be done during the planning and design stage to ensure that the installation is safe for the installers. In some circumstances the application of the CDM regulations will be required. (Projects that employ fewer than five people on site, and that last less than 30 days, or involve fewer than 500 person-days of work are exempt). All key safety issues affecting the design and installation process are discussed in the guide. The main safety issues are:

- The supply from PV modules cannot be switched off, so special precautions should be made to ensure that live parts are either not accessible or cannot be touched during installation, use and maintenance.
- PV modules are current-limiting devices, which require a non-standard approach when designing fault protection systems, as fuses are not likely to blow under short-circuit conditions.
- PV systems include d.c. wiring, with which few electrical installers are familiar.
- The installation of PV systems presents a unique combination of hazards – due to risk of electric shock, falling and simultaneous manual handling difficulty. All of these hazards are encountered as a matter of course on a building site, but rarely all at once. While roofers may be accustomed to minimising risks of falling or injury due to manual handling problems, they may not be used to dealing with the risk of electric shock. Similarly, electricians would be familiar with electric shock hazards but not with handling large objects at heights.

1.4 Parallel Generation

A mains-connected PV installation generates electricity synchronised with the electricity supply. Installers are obliged to liaise with the relevant Distribution Network Operator (DNO) in the following manner:

- Single installation covered by G83/1 – notification at or before day of commissioning followed by G83/1 paperwork (G83/1 appendix 3) within 30 days.
- Multiple installation covered by G83/1 – application to proceed (G83/1 appendix 2). On commissioning – notification and appendix 3 as above.

Note: For single installations of slightly greater than 16A attention is drawn to Note 2 in G83/1 'For the connection of small embedded generators with a rating greater than 16A per phase the DNO may choose to use this Engineering Recommendation if it is considered to be more appropriate than G59/1. For example the connection of a 5kVA PV array or a 10kVA Wind Turbine.' This would however need to be agreed in advance and in writing with the DNO.

- Larger installations under G59/1 – Written approval from DNO to be gained prior to works. Commissioning in conjunction with DNO engineer, or as required by DNO.

1.5 Note on Layout

This guide is split into two main parts, the first detailing issues that need to be addressed during the design phase of a project, and the second covering installation and sitework. It is important to note, however, that many 'design' issues covered in the first section may have a significant impact on the practical installation process covered in the second.

Throughout the guide the following format has been adopted to show the levels of authority for each guideline:

Text in blue against a shaded box with two ticks indicates mandatory and/or broadly recognised requirements ('must').



Text in blue with one tick indicates recommended practice ('should').



Text marked as notes and in italics indicates explanatory material.

1.6 Ready Reference to the Guide

Example schematics for the two main types of system are shown below to help when reading this Guide. They should not be used for a particular installation without taking into account the special circumstances of each individual installation.

a) Domestic

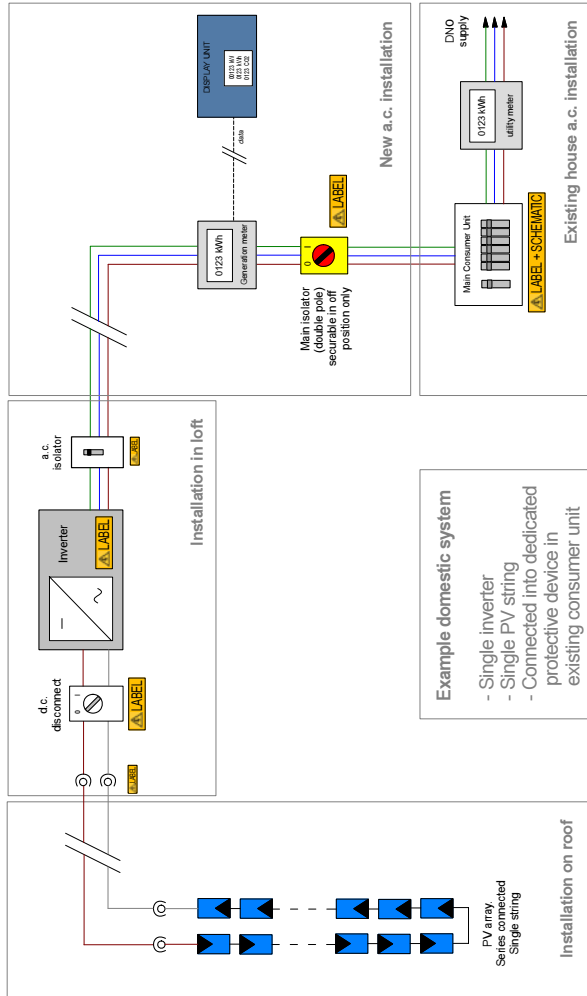

b) Commercial building

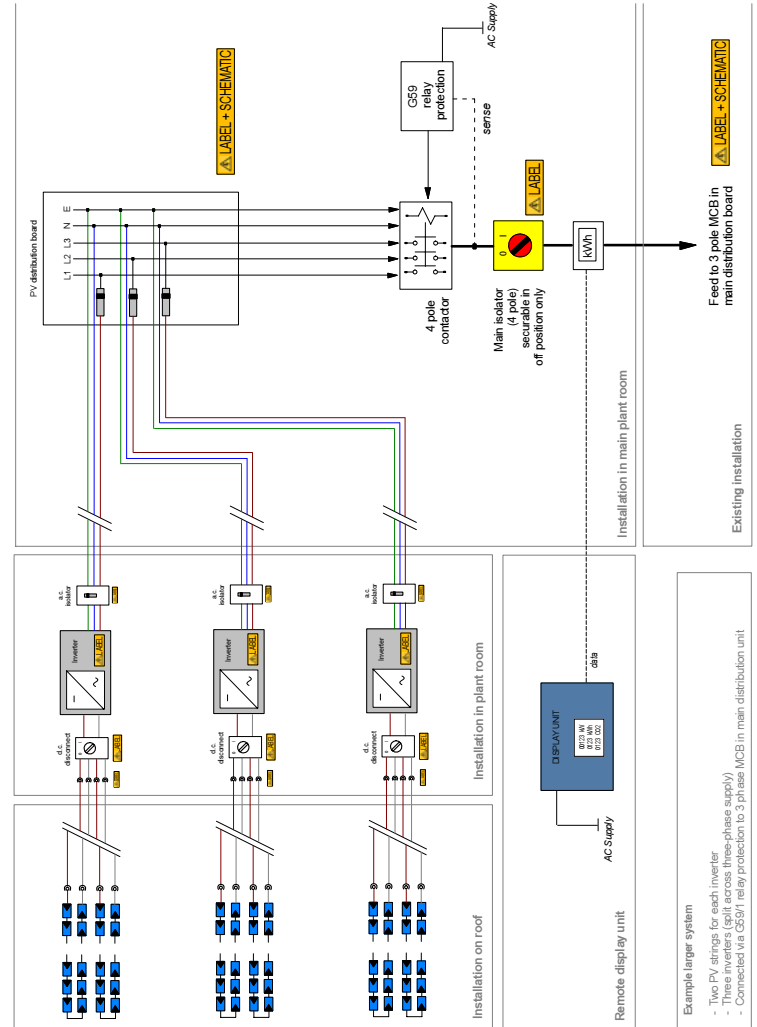

1.7 List of Terms

PV cell basic PV device which can generate electricity when exposed to light such as solar radiation

PV module smallest completely environmentally protected assembly of interconnected PV cells

PV string circuit in which PV modules are connected in series, in order for a PV array to generate the required output voltage

PV array mechanically and electrically integrated assembly of PV modules, and other necessary components, to form a d.c. power supply unit

PV array junction box enclosure where all PV strings of any PV array are electrically connected and where protection devices can be located if necessary

PV generator assembly of PV arrays

PV generator junction box enclosure where all PV arrays are electrically connected and where protection devices can be located if necessary

PV grid-connected system a PV generator operating in 'parallel' with the existing electricity network

PV string cable cable connecting PV modules to form a PV string

PV string fuse a fuse for an individual PV string

PV array cable output cable of a PV array

PV d.c. main cable cable connecting the PV generator junction box to the d.c. terminals of the PV inverter

PV inverter device which converts d.c. voltage and d.c. current into a.c. voltage and a.c. current

PV supply cable cable connecting the a.c. terminals of the PV inverter to a distribution circuit of the electrical installation

PV a.c. module Integrated module/inverter assembly where the electrical interface terminals are a.c. only. No access is provided to the d.c. side

PV installation erected equipment of a PV power supply system

PV Standard test conditions (stc) test conditions specified for PV cells and modules (25°C, light intensity 1000W/m², air mass 1.5)

PV Kilowatts peak (kWp) units for defining the rating of a PV module where = kW generated at stc

PV self-cleaning The cleaning effect on inclined PV systems from rain and wind etc

PV Charge Controller A device that provides the interface between the PV array and the battery

PV MPP Tracker Maximum Power Point Tracker – the d.c. input stage of an inverter designed to maximise the input from the array

$V_{oc(stc)}$, Open-circuit voltage voltage under standard test conditions across an unloaded (open) PV module, PV string, PV array, PV generator, or on the d.c. side of the PV inverter

$I_{sc(stc)}$, Short-circuit current short-circuit current of a PV module, PV string, PV array or PV generator under standard test conditions

d.c. side part of a PV installation from a PV cell to the d.c. terminals of the PV inverter

a.c. side part of a PV installation from the a.c. terminals of the PV inverter to the point of connection of the PV supply cable to the electrical installation

Simple separation separation provided between circuits or between a circuit and earth by means of basic insulation

Inverter Isolating Transformer where the input & output windings are electrically separated by double or reinforced insulation

Isolation A function intended to cut off for reasons of safety the supply from all, or a discrete section, of the installation by separating the installation or section from every source of electrical energy.

Isolator/ Disconnecter A mechanical switching device which, in the open position, complies with the requirements specified for isolation. An isolator is otherwise known as a disconnecter. A disconnecter is otherwise known as an isolator.

Equipotential Zone where exposed-conductive parts and extraneous-conductive parts are maintained at substantially the same voltage potential

PME – Protective Multiple Earthing where the supply neutral and earth are combined into a single conductor

Distribution Network Operator (DNO) The organisation that owns or operates a Distribution Network and is responsible for confirming requirements for the connection of generating units to that Network.

Electricity Network An electrical system supplied by one or more sources of voltage and comprising all the conductors and other electrical and associated equipment used to conduct electricity for the purposes of conveying energy to one or more Customer's installations, street electrical fixtures, or other Networks.

Islanding Any situation where a section of electricity Network, containing generation, becomes physically disconnected from the DNO's distribution Network or User's distribution Network; and one or more generators maintains a supply of electrical energy to that isolated Network.

ROCs Renewable Obligation Certificates equivalent to 1MWh of PV generation

2.0 DESIGN

2.1 Design Part 1 – d.c. System

2.1.1 PV Modules

2.1.1.1 Standard Modules

Modules must comply with the international standards: IEC 61215 in the case of crystalline types, or IEC 61646 in the case of thin film types. Modules must also carry a CE mark.

The use of Class II modules is generally recommended, and strongly recommended for array open-circuit voltages of greater than 120 V.

2.1.1.2 Building integrated products/modules

These products should comply with IEC module requirements as above. If no specific 'IEC Certificate' is available (eg for a one-off, bespoke product) a statement and evidence from the manufacturer is required to prove general compliance.

In addition, for 'integrated products' where the PV forms part of the building envelope (eg PV roof tiles), proof of compliance with relevant Building Regulations may be required by the local Building Control Inspector, eg compliance with:

- Fire resistance standards (eg BS 476- part 3)
- Relevant wind uplift and weatherproofing standards (eg BS 6399, BS 5534, BRE Digest 489).

In future it is expected that all PV products will increasingly be covered by International standard **IEC61730: 2004 'Photovoltaic (PV) module safety qualification'**.

Note: IEC61730 Part 2 – 'Requirements for testing' describes the testing requirements for photovoltaic modules in order to provide safe electrical and mechanical operation during their expected lifetime. It addresses the prevention of electrical shock, fire hazards, and personal injury due to mechanical and environmental stresses. It outlines the requirements of testing and is to be used in conjunction with IEC 61215 or IEC 61646.

2.1.2 d.c. System – minimum voltage and current ratings

All d.c. component ratings (cables, isolators/disconnectors, switches, connectors, etc) of the system must be derived from the maximum voltage and current of the PV array. This must take into account system voltage/currents of the series/parallel connected modules making up the array. It must also take into account the maximum output of the individual modules:

Mono- and multi-crystalline silicon modules :
All d.c. components must be rated, as a minimum, at:

Voltage: $V_{oc(stc)} \cdot I_{sc(stc)} \cdot 1.15$
Current: $I_{sc(stc)} \cdot 1.25$

Note: When considering the voltage and current requirements of the d.c. system, the maximum values that could occur need to be assessed. The maximum values originate from two PV module ratings – the open-circuit voltage (V_{oc}) and the short-circuit current (I_{sc}) which are obtained from the module manufacturer. The values of V_{oc} and I_{sc} provided by the module manufacturer are those at standard test conditions (stc) – irradiance of 1000 W/m^2 , air mass 1.5 and cell temperature of 25°C . Operation of a module outside of standard test conditions can considerably affect the values of $V_{oc(stc)}$, $I_{sc(stc)}$.

In the field, irradiance and particularly temperature can vary considerably from stc values. The above multiplication factors allow for the maximum values that may be experienced under UK conditions.

All other module types

All d.c. components must be rated, as a minimum, from:

- Specific calculations of worst case V_{oc} and I_{sc} , calculated from manufacturer's data for a temperature range of -15°C to 80°C and irradiance up to 1250 W/m^2**
- A calculation of any increase in V_{oc} or I_{sc} over the initial period of operation. This increase is to be applied in addition to that calculated above.**

Note: Some types of PV modules have temperature coefficients considerably different to those of standard mono- and multi-crystalline modules. The effects of increased irradiance may also be more pronounced. In such cases the multiplication factors used for crystalline silicon modules may not cover the possible increase in voltage/current.

In addition, some modules have an electrical output that is considerably higher during the first weeks of operation. This increase is on top of that produced by temperature/irradiance variation. Typically, operation during this period will take V_{oc} , I_{sc} (and nominal power output) well above any value calculated using a standard multiplication factor. To avoid oversizing for this eventuality the array could be left disconnected for that initial period.

Refer to the manufacturer for this information.

2.1.3 PV Array Design

Installations within the UK, using currently available G83/1 type approved inverters, typically operate with array voltages in the range of 120 to 500Vd.c.. However, it is to be noted that in some circumstances an array design can be implemented where the array is split into sub-arrays with an open-circuit voltage of less than 120 V.

Note: The reason for reducing below 120 Vd.c. is that d.c. represents a different hazard to a.c. While an a.c. shock causes muscular spasms which may allow the person being shocked to retract or withdraw, d.c. causes a continuous muscular contraction which may force the victim into contact for a longer period. Risk data recommends reducing the potential shock level to below 120 Vd.c. if practicable. Although a shock of 120 Vd.c. is unlikely to kill, it could cause the victim to lose balance or concentration, and so expose them to another risk, e.g. losing balance when working on a roof.

Double insulation (insulation comprising both basic & supplementary insulation, International Electrotechnical Vocabulary IEC 195-06-08), appropriate barriers and separation of parts must be applied to all systems with an open-circuit voltage of >120 Vd.c..

Class II insulation on the d.c. part of the PV system, even if less than 120 Vd.c., is strongly recommended.

Note: Double insulation of the d.c. circuit (d.c. wiring, connectors etc) greatly minimises the risk of creating accidental shock current paths (eg via damaged cable coming in contact with PV frame) and the risk of fire. Having a PV junction box with negative and positive parts well separated and protected by barriers, or better still by utilising separate enclosures, significantly reduces the potential shock risk to the installer.

Note: Though commonly used for the main d.c. cable (e.g. for long d.c. cable runs in exposed locations such as on flat roofs, or where cable is buried), sheathed and armoured cable with two or more singly insulated cores does not constitute double-insulated cable, though in this application it is acceptable as it affords a good degree of fault risk reduction (see 2.1.4.2c).

2.1.4 d.c. Cables – General

2.1.4.1 Cable sizing

Cables must be rated, as a minimum, to the voltage and current ratings derived using the multiplication factors in 2.1.2.

Standard de-rating factors must also be applied (BS 7671).

Cables should be sized such that overall voltage drop at stc between the array and the inverter is <3%.

2.1.4.2 Cable type and installation method

The cables used for wiring the d.c. section of a grid-connected PV system need to be selected to ensure that they can withstand the environmental, voltage and current conditions at which they may be expected to operate. This will include heating effects of both current and solar gain.

Note: Purpose designed “PV cables” are readily available. These are simple to use, comply with the requirements as above and allow simple and safe connection via purpose made PV plug and socket connectors. It is expected most installations would use these cables.

Cables routed behind a PV array must be rated for a minimum temperature of 80°C.

Cables must be selected so as to minimise the risk of earth faults and short-circuits. This can be achieved by reinforcing the protection of the wiring either through:

a. Single conductor cable – both insulated and sheathed (eg “PV cable”, HO7RNF cables)



b. Single conductor cable in suitable conduit/trunking (typically non conducting, however earthed metal trunking may be required where additional mechanical protection is required.) Alternatively, single core SWA may be a suitable mechanically robust solution.



c. Multi core Steel Wire Armoured SWA (only suitable for main d.c. cable and typically utilised where an underground or exposed run is needed)



External cables should be UV stable, water resistant, and it is recommended that they be flexible (multi-stranded) to allow for thermal/wind movement of arrays/modules.

Note: To minimise the risk of faults, cable runs should be kept as short as practicable. Where long cable runs are required, it is good practice to label along the d.c. cables as follows: “Danger solar PV array cable – high voltage d.c. - live during daylight”. This is to inform personnel involved in maintenance or alterations to a building at a later date. See also section 2.1.12 (additional d.c. switches for long cable runs)

Note: Where modules are supplied with pre-fitted single insulated tails, containment should be installed - as described in (b) above.

Note: New cable identification colours have been implemented under the current version of BS 7671 (see 2.3.1). The new identification colours for an unearthed d.c. circuit (typical PV circuits) are as follows:

Positive cable - Brown

Negative cable - Grey

Note: BS 7671 requires that every core of a cable shall be identifiable by colour and/or lettering/numbering at its terminations and preferably throughout its length. However, in the special case where there is no possibility of confusion, eg where cables are pre-fitted with purpose made polarised plug and socket connectors (+,-), additional cable colour/alphanumeric identification may be omitted. Binding and sleeves for identification purposes shall comply with BS 3858 as appropriate.

2.1.5 String Cables

A string is a circuit in which PV modules are connected in series, in order for a PV array to generate the required output voltage.

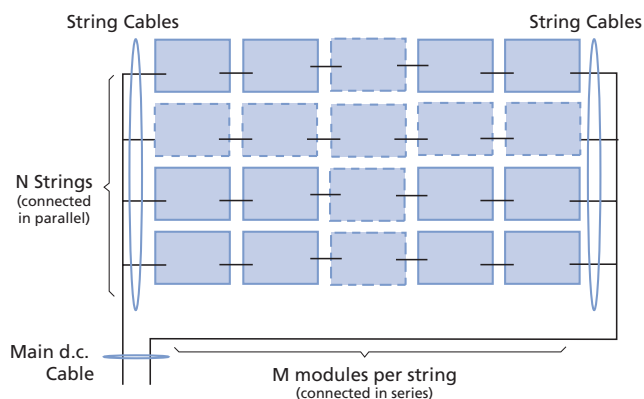

For a system of N parallel connected strings, with each formed of M series connected modules, string cables are to be rated as follows:

a. Array with no string fuses (of three or fewer strings only)

Voltage: $V_{oc(stc)} \times M \times 1.15$

Current: $I_{sc(stc)} \times (N-1) \times 1.25$

b. Array with string fuses

Voltage: $V_{oc(stc)} \times M \times 1.15$

Current: $I_{sc(stc)} \times N \times 1.25$

The sizing process for string cables in arrays with three or fewer series connected strings is valid for the majority of silicon-crystalline (conventional) modules. However, when applying this rule, a system designer must verify with the manufacturer that the individual modules are capable of withstanding a reverse current of $2 \times 1.15 \times I_{sc}$. See section 2.1.10 for further information.

Note: PV module string circuits cannot rely on conventional fuse protection for automatic disconnection of supply under fault conditions. This is because the short-circuit current is little more than the operating current – a fuse would simply not operate.

A photovoltaic cell acts as a current source, hence PV modules are current-limiting devices – even under short-circuit conditions, the output current of a module will not rise above a certain level (I_{sc}). Operating a module in short-circuit is in general of little consequence, indeed many charge controllers in battery charging systems routinely short-circuit an array output.

For small systems, the simplest approach is to ensure that the string cables are suitably rated such that they may safely carry the maximum possible fault current. This method relies on oversizing the string cables such that the fault current can be safely accommodated. Such a method does not clear the fault but simply prevents a fire risk from overloaded cables.

String fuses are required for systems of four or more strings – see string fuse section for more information. For a system with string fuses, cables may be sized by applying the standard voltage and current multiplication factors.

2.1.6 Main d.c. Cable

For a system of N parallel connected strings, with each formed of M series connected modules, d.c. main cables must be rated as a minimum at:

Voltage: $V_{oc(stc)} \times M \times 1.15$

Current: $I_{sc(stc)} \times N \times 1.25$

2.1.7 d.c. Plug and Socket Connectors

PV specific plug and socket connectors are commonly fitted to module cables by the manufacturer. Such connectors provide a secure, durable and effective electrical contact. They also simplify and increase the safety of installation works. They are recommended in particular for any installation being performed by a non-PV specialist – eg a PV array being installed by a roofer. Plug and socket “Y” connectors can also be used to replace a junction box. It is good practice to keep “Y” connectors in accessible locations and where possible note their location on layout drawings, to ease troubleshooting in future.



Connectors must be d.c. rated.

Connectors must have the same or greater voltage and current ratings as the string/d.c. main cable to which they are fitted.

A sign, 'Do not disconnect d.c. plugs and sockets under load – turn off a.c. supply first' must be fixed next to connectors, except those that are inaccessible to anyone except trained personnel in the course of PV maintenance or fault finding.

Connectors must not be used as the means for d.c. electrical switching (see 2.1.12) as d.c. arcs can cause permanent damage to some connectors.

Note: Plugs used in this application can be damaged by arc currents if disconnected under load. While connectors are sometimes suggested as an alternative to specifying a d.c.-rated switch, such use is not permitted.

Connectors should be touch safe (ie to a standard of ingress protection not less than IP 21), Class II and shrouded, and be of a design totally dissimilar in appearance to any connectors used for the a.c. system.

2.1.8 Other inline cable junctions

In general cable junctions will be either by an approved plug and socket connector or contained within a d.c. Junction Box (see below). However in certain limited circumstances it may be necessary for an in-line cable junction to be made (eg soldered extension to a module flying lead) although this should be avoided if at all possible.

Note: Great care needs to be applied in the design and installation of in-line junctions. Where unavoidable, such junctions need to maintain the 'double insulated' nature of the cables as described in section 2.1.4 (eg by the use of two layers of appropriately rated adhesive lined heat shrink sleeving), and be provided with appropriate strain relief. Such junctions would typically be done off-site, prior to works, using fittings and tools appropriate to the cable to be jointed.

2.1.9 d.c. Junction Box

If there is more than one string, the d.c. junction box is normally the point at which they are connected together in parallel. Junctions need to be made using high quality connectors, typically screw terminals. The box may also contain string fuses and test points.

The d.c. junction box must be labelled as 'PV array d.c. junction box', and also labelled with 'Danger, contains live parts during daylight'. All labels must be clear, legible, located so as to be easily visible, and durably constructed and affixed to last.

Note: A PV system cannot be turned off – terminals will remain live at all times during daylight hours. It is important to ensure that anyone opening an enclosure is fully aware of this.

A readily accessible disconnection device shall be provided to isolate individual strings. Isolation shall be provided in both positive and negative string cables.

Note: String isolation shall be achieved by any suitable means such as appropriately located plug and socket connectors or removable string fuses. Any such isolation should not be carried out with the system under load.

The short-circuit protection afforded by the cable installation throughout the rest of the d.c. circuit needs to be maintained in the construction and makeup of the d.c. junction box. (See IEC 60536 and IEC 61140).

It is recommended that short-circuit protection shall be achieved by:

- Fabrication of the enclosure from non-conductive material
- Positive and negative busbars adequately separated and segregated within the enclosure and/or by a suitably sized insulating plate, or separate positive and negative junction boxes.
- Cable and terminal layout such that short-circuits during installation and subsequent maintenance are extremely unlikely.

2.1.10 String Fuses

For a system of N parallel connected strings, with each formed of M series connected modules:

String fuses must be provided for all arrays formed of four or more strings. Fuses must be fitted in both positive and negative string cables for all strings.

- The string fuse must be rated for d.c. operation at the fault energies present
- The string fuse must be rated for operation at $V_{oc(stc)} \times M \times 1.15$
- The string fuse must have a tripping current which is less than $2 \times I_{sc}(stc)$ and the string cable current carrying capability, whichever is the lower value.

Note: The requirement for omitting string fuses in arrays with three or fewer series connected strings is valid for the majority of silicon-crystalline (conventional) modules. However, when applying this rule, a system designer must verify with the manufacturer that the module is capable of withstanding a reverse current of $2 \times 1.15 \times I_{sc}$.

For some modules, the reverse current rating provided by the manufacturer may permit more than three parallel connected strings to be installed without string fuses. In such cases, the number of strings that may be connected in parallel without the use of fuses is calculated by ensuring:

$$I_r > I_{(stc)} \times (N-1) \times 1.25$$

where I_r is the maximum permitted reverse current quoted by the module manufacturer.

The use of fuses or MCBs (miniature circuit breakers) is permissible provided they meet the above criteria and are rated for use in an inductive circuit and will operate for currents flowing in either direction through the device.

For a system of three or fewer strings with NO string fuses, string cables must have a minimum current rating of: $I_{sc} (stc) \times (N-1) \times 1.25$

Note: In a PV array formed from a number of strings, fault conditions can give rise to fault currents flowing through the d.c. system. Two key problems need addressing – overloaded string cables and significant module reverse currents, both of which can present a considerable fire risk.

Fault analysis shows that the maximum fault current flowing in a string cable to be $(N-1) \times I_{sc}$. A system of three or fewer strings cannot generate sufficient fault currents to present hazardous module reverse currents. Hence with three or fewer strings, fuses can be omitted providing that string cables are suitably rated. Such a method does not clear the fault, but simply prevents a fire risk from overloaded cables.

The installation of string fuses can provide protection against fault currents in all other cases. While some fault combinations are less likely than others, in order to provide full protection of all cables and modules – string fuses are required in both the positive and negative legs of the string cabling. (See section 2.1.5).

Note: As in section 2.1.9 it is required that some suitable means of electrical isolation be provided. This will also enable engineers to separate out individual strings for testing and tracing faults. A system fitted with suitable removable string fuses provides an ideal way to accomplish this. Thus, while it may not be necessary to fit string fuses on an array formed from two or three strings, their use may still be beneficial.

2.1.11 Blocking Diodes

Blocking diodes are not commonly used in a grid-connect system as their function is better served by the installation of a string fuse. Historically, they were specified

to prevent any reverse current flowing through parallel connected strings, much as a string fuse is intended to do. However:

- the installation of a blocking diode results in a small voltage drop across the diode;
- blocking diodes may fail as a short-circuit and therefore require regular testing. Specification of string fuses can provide sufficient reverse current protection without the problems and power losses associated with a blocking diode.

If specified, a blocking diode must have as a minimum a reverse voltage rating of $2 \times V_{oc} \times$ number of modules in the string (stc).

2.1.12 d.c. Switch

The d.c. switch provides a means of manually electrically isolating the entire PV array. Such electrical isolation is required during system installation and subsequent system maintenance or repair work. It should be located adjacent to, or integrated into the inverter.

An additional d.c. switch may be specified for systems with long d.c. cable runs (typically at the point of cable entry into the building) – so as to provide a means of isolating the cable for safety reasons or maintenance works.

- **The d.c. switch must be double pole – to effectively electrically isolate both PV array positive and PV array negative.**
- **The d.c. switch must be rated for d.c. operation.**

Note: Switching a.c. is less demanding than switching d.c. – with an a.c. supply, the voltage passes through 0 V many times a second. A switch must be rated to break d.c.; an equivalent a.c.-rated switch is not acceptable or safe.

- **The d.c. switch should be load-break rated (the use of non load-break switches is not recommended).**

- **The d.c. switch must be rated for the system voltage and current maxima as calculated in section 2.1.2.**

- **The d.c. switch (or switches) must be labelled as 'PV array d.c. isolator', with the ON and OFF positions clearly marked. Switch enclosures must also be labelled with 'Danger - contains live parts during daylight'. All labels must be clear, easily visible, constructed and affixed to last and remain legible for as long as the enclosure.**

Note: A PV array is unusual in that it cannot be turned off – terminals will remain live at all times during daylight hours. It is important to ensure that anyone opening an enclosure is fully aware of this.

An MCB may be used as a d.c. switching device provided it meets all the above requirements. The use of an MCB will provide protection against overcurrent, and so the MCB's rating must be carefully chosen so as not to operate falsely for switching surges and transients.

2.2 Design Part 2 – Earthing and Lightning Protection

Connection of parts of a PV system to earth affects:

- The electric shock risk to people in the vicinity of the installation
- The risk of fire under fault conditions
- Transmission of lightning induced surges
- Electromagnetic interference

Two types of connection to earth need consideration:

- Earthing of exposed conductive parts (eg. the array frame)
- System earths – where an array output cable is connected to earth

The earthing arrangements recommended in this guide are based upon those given in BS 7430, BS 6651 and BS 7671.

2.2.1 Earthing of exposed conductive parts (array frame)

The majority of installations will utilise class II modules, class II d.c. cables & connectors and be connected to the mains via an inverter with an isolation transformer. This approach is recommended and permits the array frame to be left floating.

Notes to terms used in diagram:

a) Isolating transformer: An isolating transformer is one in which the input and output windings are electrically separated by double or reinforced insulation (see BS 3535).

While the hazards presented by an array frame reaching the system d.c. potential may be significant, the potential fault/shock current is typically much less than that from a mains fault. Hence it is the electrical separation of the mains from the d.c. using an isolating transformer that is the key determining factor when assessing the requirement for array frame earthing.

Array Frame Earthing Decision Tree:

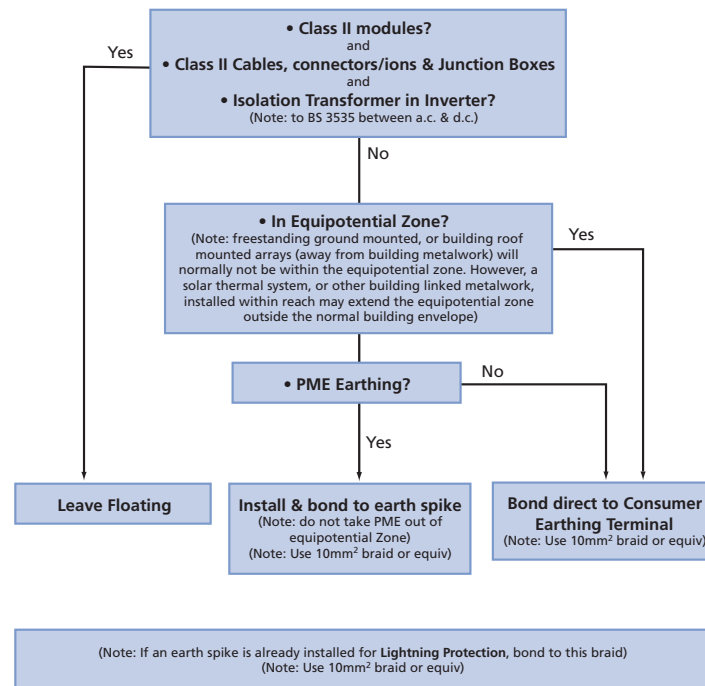

b) 'Equipotential Zone' is defined as a zone in which exposed-conductive parts and extraneous-conductive parts are maintained at substantially the same potential by bonding, such that, under fault conditions, the differences in potential between simultaneously accessible exposed and extraneous-conductive parts will not cause electric shock. 'Extraneous-conductive parts' are conductive parts liable to introduce a potential, generally earth potential, and not forming part of the electrical installation, such as a water pipe, outside tap, a metal downpipe – anything conductive that is connected to 'Earth' but not electrically part of the system.

c) PME – Protective Multiple Earthing – an earthing arrangement whereby the supply neutral and earth are combined into a single conductor. Where the incoming supply is PME (the majority of domestic supply arrangements), the PME earth cannot be taken outside the equipotential zone. This is to prevent the potential shock hazard should the supply neutral ever be lost.

2.2.2 System earthing (d.c. Conductor earthing)

The bonding to earth of any of the current carrying d.c. conductors is not recommended. However as in the note below, earthing of one of the live conductors of the d.c. side is permitted, if there is at least simple separation between the a.c. side and the d.c. side, including in the inverter.

Note: In some countries it has been the practice to bond one part of the d.c. current conductors to earth (eg earth connection at midpoint of PV string or earthed d.c. negative), or for performance reasons on certain types of modules to earth the d.c. positive. Due to the increased possible earth fault paths, and possible problems with commonly available European inverter types and internal earth fault detection circuitry, such practice should only be made when unavoidable (any connections with earth on the d.c. side should be electrically connected so as to avoid corrosion).

2.2.3 Inverter Earthing

The inverter must be treated as standard electrical apparatus and earthed as per BS 7671 if Class 1.

2.2.4 Lightning and surge protection

Lightning can cause damage either from a direct strike or from surges due to a nearby strike. Induced surges are the more likely cause of lightning damage in the majority of installations, especially in rural areas where electricity supplies are usually by long overhead lines. Surges may be induced on both the PV array conductors or the a.c. cables leading to the building.

2.2.4.1 Lightning Protection Systems

Where there is a perceived increase in risk of direct strike as a consequence of the installation of the PV system, specialists in lightning protection should be consulted with a view to installing a separate lightning protection system in accordance with BS 6651.

Note: It is generally accepted that the installation of a typical roof-mounted PV system presents a very small increased risk of a direct lightning strike. However, this may not necessarily be the case where the PV system is particularly large, where the PV system is installed on the top of a tall building, where the PV system becomes the tallest structure in the vicinity, or where the PV system is installed in an open area such as a field.

If the building or dwelling is fitted with a lightning protection system (LPS), a lightning protection installer should be consulted as to whether, in this particular case, the array frame should be connected to the LPS, and what size conductor should be used.

Note: In some cases it may be possible to forgo bonding to the LPS if the array frame is sufficiently far away from it. A system for determining whether it is necessary can be found in BS 6651 – ‘Code of Practice for Protection of Structures against Lightning’. Alternatively, consult the installers of the LPS.

Where an LPS is fitted, PV system components should be mounted away from lightning rods and down leads (see BS 6651). For example, an inverter should not be mounted on an inside wall that has a down lead running just the other side of the brickwork on the outside of the building.

2.2.4.2 Surge Protection measures

All d.c. cables should be installed to provide as short runs as possible, and positive and negative cables of the same string or main d.c. supply should be bundled together, avoiding the creation of loops in the system. This requirement for short runs and bundling includes any associated earth/bonding conductors.

Long cables (eg PV main d.c. cables over about 50 m) should be installed in earthed metal conduit or trunking, or be screened cables such as mineral insulated or armoured.

Note: These measures will act to both shield the cables from inductive surges and, by increasing inductance, attenuate surge transmission. Be aware of the need to allow any water or condensation that may accumulate in the conduit or trunking to escape through properly designed and installed vents.

Most grid connect inverters have some form of in-built surge suppression, however discrete devices may also be specified.

Note: To protect the a.c. system, surge suppression devices may be fitted at the main incoming point of a.c. supply (at the consumer’s cut-out).

To protect the d.c. system, surge suppression devices can be fitted at the inverter end of the d.c. cabling and at the array.

To protect specific equipment, surge suppression devices may be fitted as close as is practical to the device.

2.3 Design Part 3 – a.c. System

2.3.1 a.c. Cabling

An inverter supplied from a PV array must preferably be installed in a dedicated circuit in which:

- no current-using equipment is connected, and
- no provision is made for the connection of current-using equipment, and
- no socket-outlets are permitted.

An inverter must not be connected by means of a plug with contacts which may be live when exposed.

Where an electrical installation includes a PV power supply system without at least simple separation between the a.c. side and the d.c. side, an RCD installed to provide fault protection by automatic disconnection of supply must be type B RCD according to BS EN 60898 (IEC 60755, amendment 2).

a.c. cables are to be specified and installed in accordance with BS 7671.

The a.c. cable connecting the inverter(s) to the consumer unit should be oversized to minimise voltage drop. A 1% drop or less is recommended. However in larger installations this may not be practicable or economic due to the very large size of cable resulting. In this case the designer should minimise voltage drop as far as possible and must remain within voltage drop limits as prescribed by BS 7671.

Note: When generating, the voltage at the inverter terminals is higher than the voltage at the consumer unit. This voltage drop must be kept to a minimum in order to prevent the inverter nuisance tripping on over voltage.

Note: New cables colours have been implemented under the current version of BS 7671. These colour changes became mandatory on 1st April 2006. Colour changes and the requirements for labelling in mixed colour installations can be found in BS 7671 and from IEE technical publications.

2.3.2 a.c. switch-disconnector

A manual a.c. switch-disconnector must be provided located in an accessible position within the Customer's installation as in G83/1 (e.g. adjacent to the consumer unit or main distribution board), which is:

- in accordance with BS 60947-3
- must switch all live and neutral conductors.
- must be securable in the OFF position only. It must be simple to secure using a standard padlock - devices that require a separate removable

adaptor or special key to enable them to be secured are not acceptable.

- must clearly show the ON and OFF positions and be labelled as 'PV system – main a.c. isolator'.

Note: At the point of installation of any a.c. switch-disconnector, the public supply should be considered the source and the PV installation the load.

If the a.c. switch-disconnector and the inverter(s) are not in the same room a local isolator should be installed adjacent to the inverter(s). This is to facilitate maintenance of the a.c. cable run and inverter(s).

2.3.3 Inverters

Inverters must carry a Type Test certificate to the requirements of Engineering Recommendation G83/1 or comply with all other parts of ER G83/1 unless specifically agreed by an engineer employed by or appointed by the DNO for this purpose, and in writing.

Note: A key safety consideration is that the PV system will disconnect when the distribution system is not energised. This is to prevent the hazardous situation of the photovoltaic system feeding the network or local distribution system during a planned or unscheduled loss of mains. Such an event is termed 'islanding' and presents a potential danger to those working on the network/distribution system. Type Tests established through ER G83/1 ensure that an inverter is properly prevented from such islanding operation.

Other considerations addressed by ER G83/1 include the prevention of harmonics, EMC compatibility and d.c. injection.

In order to simplify the earthing requirement, an inverter with an isolating transformer is recommended (see section 2.2.1.(a)). This would protect against the possibility of a.c. exciting the d.c. side, and remove the requirement to earth the array frame, but does not override any need to connect the frame to earth for lightning protection purposes.

The inverter must be capable of withstanding the maximum array voltage and current as calculated in section 2.1.2. This must include any initial overvoltage period which is a feature of some module types.

Note: It is common practice for an inverter:array power ratio to be less than unity, (see section 2.6.1), but it is important to ensure that the inverter cannot be damaged by array peak output. This is particularly the case with some thin film PVs that have an initial overvoltage period. See also notes regarding inverter mpp operating range in section 2.6.1.

It is recommended that Inverters carry a sign 'Inverter - isolate a.c. and d.c. before carrying out work'.

2.3.4 a.c. Fault Current Protection

Short-circuit protection for the dedicated feeder cable from the inverter(s) must be provided at the consumer unit. This electrical protection is to be specified and installed in accordance with the requirements of BS 7671.

Note: Short-circuit protection is not required at the inverter output. If using an RCD for a.c.-side earth fault protection, see section 2.3.1.

2.3.5 Metering

Inverter output meter: As a minimum, metering at the inverter output should be installed to display/record energy delivered by the PV system (kWh). In addition it is highly recommended for instantaneous power output (kW) to be displayed. This will not only add to customer satisfaction it should lead to more effective fault detection. A kWh meter approved by OFGEM is recommended as it may facilitate payment on ROCs and other Electricity company scheme payments as they become available.

The meter should be located where the consumer can readily observe it.

Building Export meter: Although not directly part of the PV system, in order to enable payment on exported electricity, a kWh export meter approved by OFGEM with appropriate meter reading may be required. The appropriate Electricity Supplier should be contacted to find out any particular requirements and to arrange for its fitting.

2.4 Design Part 4 – Design Approval

2.4.1 DNO approval

A mains-connected PV installation generates electricity synchronised with the electricity supply.

Installers are obliged to liaise with the relevant distribution Network Operator (DNO) in the following manner:

- **Single installation covered by G83/1 – notification at or before day of commissioning followed by G83/1 paperwork (G83/1 appendix 3) within 30 days.**
- **Multiple installation covered by G83/1 – application to proceed (G83/1 appendix 2). On commissioning – notification and appendix 3 as above.**

Note: For single installations of slightly greater than 16A attention is drawn to Note 2 in G83/1 'For the connection of small embedded generators with a rating greater than 16A per phase the DNO may choose to use this Engineering Recommendation if it is considered to be more appropriate than G59/1. For example the connection of a 5kVA PV array or a 10kVA Wind Turbine.' This would however need to be agreed in advance and in writing with the DNO.

- **Larger installations under G59/1 – Written approval from DNO to be gained prior to works. Commissioning in conjunction with DNO engineer, or as required by DNO.**

2.4.2 Planning permission

Guidance regarding the requirements for planning permissions for PV systems can be obtained in PPS22 'Planning Policy Statement 22: Renewable Energy' (ISBN 0 11 753924 4, 2004 - available from www.odpm.gov.uk).

The relevant planning authority and building control should be consulted at an early stage to determine any requirements that may apply.

Note: Planning permission will be mainly concerned about the visual impact of the PV system. Typically, for domestic installations, planning permission is not required (can vary where property is affected by restrictions such as a conservation area, etc).

Building Regulations approval may require the product to have passed the wind uplift, water penetration and spread of flame tests (see section 2.1.1.2). These will usually be applicable only where the PV is integrated into the fabric of the building.

2.4.3 Building Regulations – Part P (Electrical safety)

From 1st January 2005, people undertaking electrical work in homes and gardens in England and Wales must follow new rules in Building Regulations - Part P.

The changes have been made to:

- Ensure the safety of electrical installations
- Ensure records are kept of work done
- Provide electrical safety certificates that verify conformity of work – these may be integrated into property selling requirements

Virtually all domestic PV installations will fall under the scope of Part P. Part P requires the relevant Building Control department to be notified and approve the work. There are two routes to comply with the requirements of Part P:

- Notify the relevant Building Control department before starting the work. Documentation will be required and a site inspection by a Building Control officer may occur. Building Control charges may apply.

- Where a contractor is registered with a Competent Person Scheme (as approved by the office of the deputy prime minister), Building Control can be supplied with relevant documentation after the work is completed. Documentation is self certified under the Competent Person Scheme and a site visit by Building Control is not normally required.

Part P also reinforces the requirement for the provision of an Electrical Installation Certificate (to the requirements of BS 7671) – see section 4.1.

Note: A copy of the 'Building Notice' notification form can be found on the Local Authority Building Control website www.labc-services.co.uk.

Note: At the time of writing, there are no 'defined scope' competent persons schemes to cover the installation of PV systems. Until a PV defined scope scheme is available, full scope schemes are applicable.

2.5 Battery Systems

This section of the guide covers the additional requirements where a battery forms part of a PV installation – whether as part of a true stand-alone (off-grid) system or part of a hybrid (e.g. grid-linked/ batteries) system.

Note: The design and requirements of any of the load circuits within such a system are outside the scope of this document.

2.5.1 PV array charge controller

This provides the regulator/dump interface between the PV array and the battery so as to prevent overcharging of the battery. The unit may also provide other functions such as maximum power point tracking, voltage transformation, load control and metering.

Example Battery System

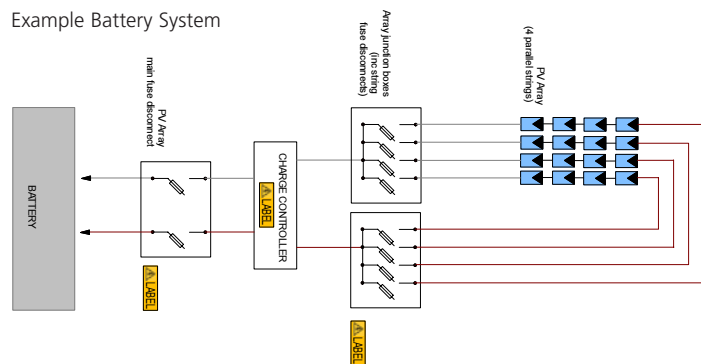

- The charge controller must be rated for the current and voltage maxima (see Section 2.1.2, minimum voltage and current ratings)
- The charge controller must be labelled as per the d.c. junction box requirements in section 2.1.9.
- The charge controller must carry a CE Mark.

A full recharge is important for good battery health. A small size cable between the charge control unit and the battery – with an associated high voltage drop – may lead to the control system prematurely halting the charge cycle. These cables should therefore be sized for a maximum voltage drop of less than 1% at peak PV array output. For controllers with a separate battery sense function, a fused battery sense cable can be installed.

2.5.2 Battery over current protection

A battery stores significant energy and has the capacity to deliver large fault currents. Proper fault protection must be provided.

An over current device must be installed in all active (non-earthed) conductors between the battery and the charge controller.

The over current device (either a fuse or circuit-breaker) must:

- have a trip value as specified within the charge controller manual
- be rated for operation at d.c., at 125% of the nominal battery voltage
- have an interrupt rating greater than the potential battery short-circuit current.

The length of cable between the over current device and battery terminal must be as short as practicable.

2.5.3 Battery disconnection

A means of manual isolation must be provided between the charge controller and the battery, either combined with the over current device or as a separate unit. The isolator must be double pole, d.c. rated and load break, and the length of the cable between it and the battery must be as short as practicable.

Isolation is to be installed and the system designed so that the PV array cannot directly feed the loads when the battery has been disconnected.

Combined fault protection and isolation:

- A circuit-breaker provided for battery fault current protection may be used to provide isolation, if it is rated as an isolation device.
- A fuse assembly provided for fault current protection may be used to provide isolation if it has readily removable fuses (eg fuse unit with disconnect mechanism)



2.5.4 Cables in battery systems

The requirements set out in the main sections of this guide apply:

Note: In some circumstances, a voltage drop greater than that in section 2.1.4.1 may be justified on economic grounds.

In addition:

All cables must have a current rating above that of the relevant over current device (nearest downstream fuse / circuit breaker). Cable current ratings are to be adjusted using standard correction factors for installation method, temperature, grouping and frequency to BS 7671.

2.5.5 PV String cable and fuse ratings

String cables (upstream of the charge controller) must be rated to the trip current of the nearest downstream device plus the rating as calculated in section 2.1.5.

A PV–battery system must be designed such that the string cable/ string fuse design and specification reflects that fault currents may come either from the array itself, from the battery or from both. Again, cable current ratings are to be adjusted using standard correction factors for installation method, temperature, grouping and frequency to BS 7671.

Note: Specification & labelling for the PV cables/ junction boxes/ connectors/ etc should be as in the main sections of the guide.

2.5.6 Battery selection and sizing

The selection of a battery is generally out of the scope of this document. However, some key considerations to be flagged are:

- is the battery fit for purpose, i.e. appropriately rated for its duties? In the majority of cases a true ‘deep cycle’ battery will be required
- does it have an adequate storage capacity and cycle life?
- is a sealed or vented battery more appropriate for the particular installation?
- will the battery be made up of series cells or parallel banks? While series cells will generally give better performance, practical considerations may influence the design. In general, though, banks with more than four parallel units are to be avoided.

The sizing of a battery is generally out of the scope of this document. However, for an effective charging regime where a PV array is the only charge source, the battery would normally be sized so that the output of the PV array falls between the manufacturer’s maximum and minimum recommended charge rates.

Charge/discharge rates (C) are commonly expressed as an hourly rate derived from the formula: $\text{Rate} = \text{Capacity (Ah)} / \text{Time (h)}$

For example, a C10 charge rate for a 500Ah battery would take place at 50A.

Charge rates between C5 and C20 are often used in systems with vented lead acid batteries, for example.

2.5.7 Battery installation/labelling

In an enclosed location, ventilation must be provided to battery installations with an air inlet at low level and an outlet at the highest point in the room or enclosure.

Sufficient ventilation is needed to remove battery gases. It is particularly important in the case of vented lead acid units as hydrogen is given off during charging – and a concentration of more than 4% creates an explosion hazard. Ventilation also prevents excessive heat build up.

BS 6133 ‘Safe operation of lead acid stationary batteries’ gives a procedure for calculating ventilation requirements.

Battery banks must be housed in such a way that (BS 6133):

- access can be restricted to authorised personnel
- adequate containment is assured
- appropriate temperature control can be maintained

Battery terminals are to be guarded so that accidental contact with persons or objects is prevented.

The ideal operating temperature for a lead acid battery is around 25°C, temperatures significantly above or below this will lead to reduced lifetime and capacity. Indeed, at very low temperatures, discharged batteries may freeze and burst; at high temperatures, thermal runaway can occur in sealed batteries.

Items which could produce sparks (e.g. manual disconnects, relays) should not be positioned within a battery box or directly above one.

Battery gases are corrosive, so cables and other items inside a battery enclosure need to be corrosion resistant. Sensitive electronic devices should not be mounted in, or above, a battery box.

To ensure proper load/charge sharing in a battery bank made up of units connected in parallel, the units need to have the same thermal environment and

the same electrical connection resistance.

In larger battery banks, fusing each parallel unit should be considered.

A typical connection configuration for a small series-parallel battery bank (take-offs are on opposite corners)

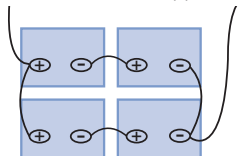

The following warning signs are to be displayed:

- No Smoking or Naked Flames
- Batteries contain acid – avoid contact with skin or eyes
- Electric shock risk – xxx Vd.c.

Note: Circuit protection, and all points of isolation should also be labelled with “d.c. Supply – xxx Vd.c.”

All labels should be clear, easily visible and should be constructed and fixed so as to remain legible and in place throughout the design life of the system.

Protective equipment, including appropriate gloves and goggles – together with an eye wash and neutralising agent – should be stored adjacent to the battery installation.

2.6 System performance

2.6.1 Inverter sizing

It is common practice for an inverter power to be less than the PV array rating and safety considerations with respect to sizing an inverter are addressed in section 2.3.3. However, also to be considered is the system performance.

For example, a 1kWp array connected to a 1.5kW inverter may be safe but not energy efficient – with the UK climate, the inverter will be operating for much of the time at less than the 1kWp rating of the array and consequently at a poor point on the inverter efficiency curve depending on the inverter (inverters are typically less efficient at low power levels).

PV array: inverter ratios from 1:1 to 1:0.8 are commonly applied in the UK, though in certain circumstances and depending on the inverter used, ratios

outside this are sometimes utilised (NB: Inverter power is taken to be maximum steady state a.c. power output).

Guidance on inverter : array sizing can be obtained from the inverter manufacturers – typically from system sizing software.

Inverter mpp range - An inverter must be able to safely withstand the maximum array voltage and current as stated in section 2.3.3. However, when choosing the most appropriate inverter, for inverter performance purposes and when considering the matching of an array to the mpp range of an inverter, an assessment can be made as to whether a narrower temperature band (e.g. -10°C to 70°C) may be acceptable and appropriate for that particular site.

2.6.2 System performance

The output of a PV system depends on many factors such as orientation, pitch, shading and geographical location.

Estimating exact annual performance of a grid connected PV system is difficult, however as a rule of thumb - a south facing, inclined plane, unshaded array in the UK can be expected to generate on average 750 kWh per kWp installed per year. Please note that this can be a conservative figure.

Note: These figures are typical for the UK - up to +/-10% difference can be expected depending on position in the country and type of PV cells used etc - it is recommended that a PV simulation is carried out using one of the PV simulation programmes available for an accurate estimation.

Orientation Chart - Showing % of yearly output available for various orientation tilts (as % of maximum)

		Orientation - Compass bearing (°) measured from North												
		West 270°	255°	240°	SW 225°	210°	195°	South 180°	165°	150°	SE 135°	120°	105°	EAST 90°
Tilt (°) from Horiz.	Horiz. 0°	90	90	90	90	90	90	90	90	90	90	90	90	90
	10°	89	91	92	94	95	95	96	95	95	94	93	91	90
	20°	87	90	93	96	97	98	98	98	97	96	94	91	88
	30°	85	89	93	96	98	99	100	100	98	96	94	90	86
	40°	82	86	90	95	97	99	100	99	98	96	92	88	84
	50°	78	84	88	92	95	96	97	97	96	93	89	85	80
	60°	74	79	84	87	90	91	93	93	92	89	86	81	76
	70°	69	74	78	82	85	86	87	87	86	84	80	76	70
	80°	63	68	72	75	77	79	80	80	79	77	74	69	65
	Vert. 90°	56	60	64	67	69	71	71	71	71	69	65	62	58

Note: Near horizontal 0° inclinations are not recommended as the self-cleaning can not be relied on up to about 10°.



Output varies with season. The shape of the daily insolation curves, and the monthly and seasonal trend in system performance is shown on the graphs below:

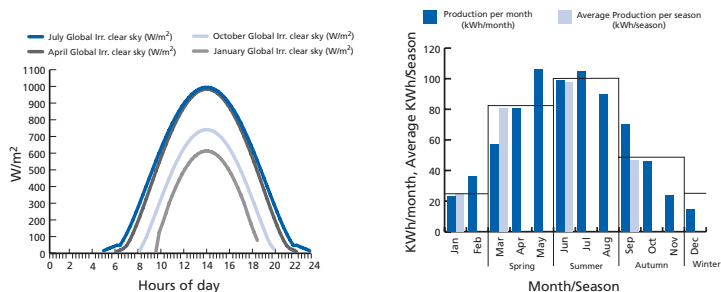

Example average daily insolation curves: Manchester, 30° Inclination, due South. Ref: European Joint Research Centre, <http://re.jrc.ec.eu.int/pvgis/pv/> PVGIS@European Communities, 2002-2006

Example average kWh electricity generation bar chart: Manchester, 30° Inclination, due South, 750kWh/yr Ref: European Joint Research Centre, <http://re.jrc.ec.eu.int/pvgis/pv/> PVGIS@European Communities, 2002-2006

Shading – Shade makes a big impact on the performance of a PV system. Even a small degree of shading on part of an array can have a very significant impact on the overall array output. Shade is one element of system performance that can be specifically addressed during system design – by careful selection of array location and layout and in the electrical design (string design to ensure shade effects only one string).

Module temperature – An increase in module temperature results in a decrease in performance (eg 0.5% per 1°C above stc for a crystalline module). Sufficient ventilation must be provided behind an array for cooling (typically a minimum 25mm vented air gap to the rear). For building integrated systems, this is usually addressed by the provision of a vented air space behind the modules. On a conventional pitched roof, batten cavity ventilation is typically achieved by the use of counterbattens over the roof membrane and by the installation of eaves and ridge ventilation.

Note: It may be possible to omit counterbattens with some integrated PV roofing products / roof construction. This is acceptable where there is test data showing that a specific integrated PV product and associated roof construction provide a similar PV cell temperature performance to a roof with a ventilated counterbatten space.

Inverter ventilation – Inverters dissipate heat and should be provided with sufficient ventilation. Clearance distances as specified by the manufacturer (e.g to a heatsink) should also be observed. Failure to follow this can cause a loss in system performance as the inverter will de-rate when it reaches its maximum operating temperature. This should be highlighted within the O&M manual and perhaps with a label – not to block ventilation – placed next to the inverter.

3.0 INSTALLATION/SITWORK

3.1 General

Standard health and safety practice and conventional electrical installation practice must apply to the installation of a PV system. Issues such as working on roofs or standard domestic a.c. wiring are covered thoroughly in other publications (e.g. see HSE website www.hse.gov.uk) and are not detailed in this guide.

3.2 PV Specific Hazards

When compiling a method statement and risk assessment for the installation of a PV system, there are a number of PV specific hazards that need to be addressed. These will be in addition to standard considerations such as PPE (Personal Protective Equipment), working at height, manual handling, handling glass and the application of the CDM regulations.

- PV modules produce electricity when exposed to daylight and individual modules cannot be switched off. Hence, unlike most other electrical installation work, the electrical installation of a PV system typically involves working on a live system. See requirements of Regulation 14 of Electricity at Work Regulations 1989.
- As current limiting devices, PV module string circuits cannot rely on fuse protection for automatic disconnection of supply under fault conditions, as the short-circuit current is little more than the operating current. Once established, a fault may remain a hazard, perhaps undetected, for a considerable time.
- Good wiring design and installation practice will serve to protect both the system installers and any persons subsequently coming into contact with the system from an electric shock hazard (operator, owner, cleaner, service engineers, etc).
- Undetected, fault currents can also develop into a fire hazard. Without fuse protection to clear such faults, protection from this fire hazard can be achieved only by both a good d.c. system design and a careful installation.
- PV presents a unique combination of hazard – due to risk of shock, falling, and simultaneous manual handling difficulty. All of these hazards are encountered as a matter of course on a building site, but rarely all at once. While roofers may be accustomed to minimising risks of falling or injury due to manual handling problems, they may not be used to dealing with the risk of electric shock. Similarly, electricians would be familiar with electric shock hazards but will not be used to handling large objects at heights.

Hazards associated with PV installation are outlined in the DTI's free manual, 'Photovoltaics in Buildings – Safety and the CDM Regulations'.

3.3 d.c. Circuits - installation

3.3.1 Personnel

All persons working on the live d.c. cabling of a Photovoltaic (PV) system must be experienced/trained in working with such systems and fully acquainted with the voltages present on that system in particular.

Plug and socket connectors simplify and increase the safety of installation works – see section 2.1.7. They are recommended in particular for any installation being performed by a non-PV specialist – eg a PV array being installed by a roofer.

3.3.2 Sequence of works

All d.c. wiring should if possible be completed prior to installing a PV array. This will allow effective electrical isolation of the d.c. system (via the d.c. switch-disconnector and PV module cable connectors) while the array is installed; and effective electrical isolation of the PV array while the inverter is installed.

Typically this would require an installation of:

- d.c. switch-disconnector and d.c. junction box(es)
- String/array positive and negative cables – from the d.c. disconnect/junction box to either end of the PV string/array;
- PV array main cables from d.c. switch to inverter.

This should be carried out in such a way that it should never be necessary for an installer to work in any enclosure or situation featuring simultaneously accessible live PV string positive and negative parts.

Note: While the installer will be handling live cables during the subsequent module installation, because the circuit is broken at the d.c. switch-disconnector, there is no possibility of an electric shock current flowing from the partially completed PV string. The maximum electric shock voltage that should ever be encountered is that of one individual PV module.

Where it is not possible to pre-install a d.c. isolator (eg a new-build project where a PV array is installed prior to the plant room being completed), cable ends/ connectors should be put temporarily into an isolation box and suitably labelled (as per d.c. junction box – section 2.1.9).

Cables are to be well supported, especially those cables exposed to the wind. Cables must be routed in prescribed zones or within mechanical protection. They must also be protected from sharp edges.

3.3.3 Live working

If it is unavoidable to work in any enclosure or situation featuring simultaneously accessible live PV string positive and negative parts, this must be performed either by utilising insulating gloves, tools, insulating materials for shrouding purposes and appropriate personal protective equipment (see Regulations 4(4), 14 and 15 of Electricity at Work Regulations 1989; HSE HSG 85; and BS EN 60903 and BS EN 60900) or by covering the PV array; or by working at night (with appropriate task lighting). When covering PV panels during installation, the covering must be opaque, cover the whole array and be well secured.

A temporary warning sign and barrier must be posted for any period while live PV array cables or other d.c. cables are being installed.

Note: Covering a PV array can provide a means to prevent the need for live working. In practice, however, this is often difficult due to the practical problems of keeping the array covered as the installation proceeds and protecting the covering from the effects of the weather.

3.3.4 Shock hazard (safe working practices)

It is important to note that, despite all the above precautions, an installer or service engineer may still encounter an electric shock hazard:

Always test for the presence of voltage of parts before touching any part of the system.

Where a residual electric shock hazard is encountered, live working practices must be adopted (see above).

An electric shock may be experienced from a capacitive discharge – a charge may build up in the PV system due to its distributed capacitance to ground. Such effects are more prevalent in certain types of modules and systems, namely amorphous (thin film) modules with metal frames or steel backing. In such circumstances, appropriate and safe live working practices must be adopted.

An example of where such hazards may be encountered is the case where an installer is seated on earthed metal roof wiring a large PV array. In such circumstances the installer must touch the PV cabling and can get an electric shock to earth. The electric shock voltage will increase with the number of series connected modules. The use of insulated tools and gloves, together with insulating matting to stand or sit on, can mitigate this hazard.

An electric shock may also be experienced due to the PV array developing a ground leakage path. Good wiring practice, double insulation and modules of Class II construction can significantly reduce this problem, but in any installed systems, leakage paths may still occur. Any person working on a PV system must be aware of this and take the necessary precautions.

4.0 SYSTEM INSPECTION, TESTING & COMMISSIONING REQUIREMENTS, DOCUMENTATION & LABELLING

4.1 Inspection and testing

Inspection and testing of the completed system to the requirements of BS 7671 must be carried out and documented. Provision of this documentation is a requirement of Part P of the Building Regulations (see section 2.4.2)

The inspection and testing of a.c. circuits is comprehensively covered within BS 7671 and supporting technical guides. Inspection and testing documentation typically comprises 3 forms – an installation certificate, which includes a schedule of items inspected and a schedule of test results.

The inspection and testing of d.c. circuits, particularly testing PV array circuits requires special considerations. Appendix C covers the inspection and testing of PV array circuits and documentation to be provided.

4.2 Array commissioning tests

PV array/string performance tests are recommended to verify performance as a check for faulty modules. These will entail additional tests over and above those set out in BS 7671 and the associated guidance. This may require a means of measuring solar radiation for larger installations if radiation levels are changing during testing.

Simultaneous monitoring of the solar radiation can present practical difficulties unless the system has a radiation sensor installed and its cable is accessible at the place where testing is carried out. If radiation conditions are reasonably constant (ie no sudden obscuring of direct sunlight by clouds), comparing one open-circuit string voltage with another will identify faulty strings.

Guidance on commissioning tests can also be found in appendix C.

4.3 E.R. G83/1 and G59/1 commissioning

As noted in section 2.4.1 in order to satisfy the requirements of the distribution Network Operator, various tests and documentation needs to be provided. See section 1.4 and 2.4.1 for more details on the process to be followed depending on the size of system.

Compliance with DNO requirements will include:





- Inverters should be programmed such that the automatic protection system operates at :
 - Operating voltage greater than 264 V phase to neutral
 - Operating voltage less than 207 V phase to neutral
 - Operating frequency greater than 50.5 Hz
 - Operating frequency less than 47 Hz

- Dual supply labelling should be provided at the service termination, meter position and all points of isolation to indicate the presence of on-site generation and indicating the position of the main a.c. switch disconnector (for suitable label see ER G83/1 or see the sample reproduced in 'Example Signs' and on the back cover of this guide).

- At the point of interconnection, the following information is to be displayed (typically all displayed on the circuit diagram):
 - Circuit diagram showing the relationship between the inverter equipment and supply.
 - A summary of the protection settings incorporated within the equipment.
 - A contact telephone number for the supplier/installer/maintainer of the equipment.

NB It is also good practice for shutdown and start-up procedures to be detailed on this diagram.

Note: the requirements for larger systems connected under G59/1- including commissioning tests (which may need to be witnessed) are to be confirmed with the relevant DNO engineer as part of the connection application process.





4.4 Labelling

Requirements for labelling are contained within the relevant sections of this guide. Example labels can be seen below.



All labels must be clear, easily visible, constructed and affixed to last and remain legible for the lifetime of the system.

Sign No. Example Signs See Section

1	 PV Array d.c. Junction Box. Danger - contains live parts during daylight.	2.1.9
2	 Do not disconnect d.c. plugs and sockets under load - turn off a.c. supply first.	2.1.7
3	 PV array d.c. isolator. Danger - contains live parts during daylight.	2.1.12
4	 Inverter - Isolate a.c. and d.c. before carrying out work.	2.3.3
5	 PV system - main a.c. isolator.	2.3.2

6	  <div style="background-color: red; color: white; padding: 5px; display: inline-block;">Do not work on this equipment until it is isolated from both mains and on-site generation supplies</div>	4.3
	WARNING dual supply Isolate on-site generator at _____ Isolate mains supply at _____	

4.3

4.5 Operation & maintenance manual

The user manual should include as a minimum the following information:

System data

- A copy of the basic system information
- A single line electrical schematic.
- A copy of the manuals and data sheets for the following system components:
 - PV modules
 - Inverter
 - Other relevant product documentation.

Test results & commissioning data

- A copy of the test & commissioning documentation (see Appendix A, B & C)
- Table of inverter protection settings (under/over voltage, under/over frequency, etc).

Operation & maintenance data

- Procedures for verifying correct system operation.
- A checklist of what to do in case of a system failure.
- Shutdown/isolation and startup procedures.
- Maintenance & cleaning recommendations (if any)
- Considerations for any future building works adjacent to the PV array (eg roof works) to avoid potential damage or shading of the PV array.

Warranty

- Warranty Information

G83/1 INSTALLATION COMMISSIONING CONFIRMATION FORM

This form is courtesy of the Energy Networks Association (ENA) and can be downloaded from www.energynetworks.org/word/ER_G3-1_Appendix_3.doc

Engineering recommendation G83/1.SSEG installation commissioning confirmation

Confirmation of commissioning of a SSEG unit connected in parallel with the public distribution network - in accordance with Engineering Recommendation G83/1. One Commissioning Pro-forma per installation is to be submitted to the DNO.

Site details

Property address (inc. post code)	
Telephone number	
Customer supply number (MPAN)	
Distribution Network Operator (DNO)	

Contact details

SSEG owner	
Contact person	
Contact telephone number	

SSEG details

Manufacturer and model type	
Serial number of SSEG	
Serial number/version numbers of software (where appropriate)	
SSEG rating (A) and power factor (under normal running conditions)	
Maximum peak short-circuit current (A)	
Type of prime mover and fuel source	
Location of SSEG unit within the installation	
Location of multi pole isolator	

Installer details

Installer	
Accreditation/Qualification	
Address (incl post code)	
Contact person	
Telephone number	
Fax number	
E-mail address	

Information to be enclosed

Final copy of system schematic	
SSEG Test Report (Appendix 4) or web address if appropriate (not necessary if already provided e.g. under stage 2 connection)	
Computer print out (where possible) or other schedule of protection settings	
Electricity meter(s) make and model	

Declaration - to be completed by installer

The SSEG installation complies with the relevant sections of Engineering Recommendation G83/1	
Protection settings have been set to comply with Engineering Recommendation G83/1	
The protection settings are protected from alteration except by prior written agreement between the DNO and the Customer or his agent	
Safety labels have been fitted in accordance with section 6.1 of Engineering Recommendation G83/1	
The SSEG installation complies with the relevant sections of BS 7671 and an installation test certificate is attached	
Comments (continue on separate sheet if necessary)	
Name	Signature
	Date

ELECTRICAL INSTALLATION CERTIFICATE

Note: This certificate is courtesy of the Institution of Engineering and Technology and can be downloaded from www.theiet.org/publications. A schedule of items inspected, together with a schedule of test results, are to be included as part of this certificate.

Form 2

Form No /2

ELECTRICAL INSTALLATION CERTIFICATE (notes 1 and 2)
(REQUIREMENTS FOR ELECTRICAL INSTALLATIONS - BS 7671 (IEE WIRING REGULATIONS))

DETAILS OF THE CLIENT (note 1)

INSTALLATION ADDRESS

 Postcode

DESCRIPTION AND EXTENT OF THE INSTALLATION Tick boxes as appropriate (note 1)
 Description of installation:
 Extent of installation covered by this Certificate:

New installation
 Addition to an existing installation
 Alteration to an existing installation

FOR DESIGN
 I/We being the person(s) responsible for the design of the electrical installation (as indicated by my/our signatures below), particulars of which are described above, having exercised reasonable skill and care when carrying out the design hereby CERTIFY that the design work for which I/we have been responsible is to the best of my/our knowledge and belief in accordance with BS 7671 : amended to (date) except for the departures, if any, detailed as follows:
 Details of departures from BS 7671 (Regulations 120-01-03, 120-02):

The extent of liability of the signatory or the signatories is limited to the work described above as the subject of this Certificate.
 For the DESIGN of the installation: (Where there is mutual responsibility for the design)
 Signature: Date: Name (BLOCK LETTERS): Designer No 1
 Signature: Date: Name (BLOCK LETTERS): Designer No 2**

FOR CONSTRUCTION
 I/We being the person(s) responsible for the construction of the electrical installation (as indicated by my/our signatures below), particulars of which are described above, having exercised reasonable skill and care when carrying out the construction hereby CERTIFY that the construction work for which I/we have been responsible is to the best of my/our knowledge and belief in accordance with BS 7671 : amended to (date) except for the departures, if any, detailed as follows:
 Details of departures from BS 7671 (Regulations 120-01-03, 120-02):

The extent of liability of the signatory is limited to the work described above as the subject of this Certificate.
 For CONSTRUCTION of the installation:
 Signature Date
 Name (BLOCK LETTERS) Constructor

FOR INSPECTION & TESTING
 I/We being the person(s) responsible for the inspection & testing of the electrical installation (as indicated by my/our signatures below), particulars of which are described above, having exercised reasonable skill and care when carrying out the inspection & testing hereby CERTIFY that the work for which I/we have been responsible is to the best of my/our knowledge and belief in accordance with BS 7671 : amended to (date) except for the departures, if any, detailed as follows:
 Details of departures from BS 7671 (Regulations 120-01-03, 120-02):

The extent of liability of the signatory is limited to the work described above as the subject of this Certificate.
 For INSPECTION AND TEST of the installation:
 Signature Date
 Name (BLOCK LETTERS) Inspector

NEXT INSPECTION (notes 4 and 7)
 I/We the designer(s), recommend that this installation is further inspected and tested after an interval of not more than years/months.

PARTICULARS OF SIGNATORIES TO THE ELECTRICAL INSTALLATION CERTIFICATE (note 3)			
Designer (No 1) Name: _____ Company: _____ Address: _____ Postcode: _____ Tel No: _____			
Designer (No 2) (if applicable) Name: _____ Company: _____ Address: _____ Postcode: _____ Tel No: _____			
Constructor Name: _____ Company: _____ Address: _____ Postcode: _____ Tel No: _____			
Inspector Name: _____ Company: _____ Address: _____ Postcode: _____ Tel No: _____			
SUPPLY CHARACTERISTICS AND EARTHING ARRANGEMENTS <small>Tick boxes and enter details, as appropriate</small>			
Earthing arrangements	Number and Type of Live Conductors	Nature of Supply Parameters	Supply Protective Device Characteristics
TN-C <input type="checkbox"/>	a.c. <input type="checkbox"/> d.c. <input type="checkbox"/>	Nominal voltage, U ₀ ⁽¹⁾ _____ V	Type: _____
TN-S <input type="checkbox"/>	1-phase, 2-wire <input type="checkbox"/> 2-pole <input type="checkbox"/>	Nominal frequency, f ⁽¹⁾ _____ Hz	Nominal current rating _____ A
TN-C-S <input type="checkbox"/>	1-phase, 3-wire <input type="checkbox"/> 3-pole <input type="checkbox"/>	Prospective fault current, I _p ⁽²⁾ _____ kA (note 6)	
TT <input type="checkbox"/>	2-phase, 3-wire <input type="checkbox"/> other <input type="checkbox"/>	External loop impedance, Z _e ⁽²⁾ _____ Ω	
IT <input type="checkbox"/>	3-phase, 3-wire <input type="checkbox"/>	<small>(Note: (1) by enquiry, (2) by enquiry or by measurement)</small>	
Alternative source of supply (to be detailed on attached schedules) <input type="checkbox"/>	3-phase, 4-wire <input type="checkbox"/>		
PARTICULARS OF INSTALLATION REFERRED TO IN THE CERTIFICATE <small>Tick boxes and enter details, as appropriate</small>			
Means of Earthing	Maximum Demand		
Distributor's facility <input type="checkbox"/>	Maximum demand (load) _____ Amps per phase		
Installation earth electrode <input type="checkbox"/>	Details of Installation Earth Electrode (where applicable)		
	Type (e.g. rod(s), tape etc)	Location	Electrode resistance to earth _____ Ω
Main Protective Conductors			
Earthing conductor: material _____ csa _____ mm ² connection verified <input type="checkbox"/>			
Main equipotential bonding conductors: material _____ csa _____ mm ² connection verified <input type="checkbox"/>			
To incoming water and/or gas service <input type="checkbox"/>	To other elements _____		
Main Switch or Circuit-breaker			
BS, Type _____ No. of poles _____ Current rating _____ A Voltage rating _____ V			
Location _____ Fuse rating or setting _____ A			
Rated residual operating current I _{Δn} = _____ mA, and operating time of _____ ms (at I _{Δn}) <small>(applicable only where an RCD is suitable and is used as a main circuit-breaker)</small>			
COMMENTS ON EXISTING INSTALLATION: <small>(In the case of an alteration or additions see Section 742)</small>			

SCHEDULES (note 2)			
<small>The attached Schedules are part of this document and this Certificate is valid only when they are attached to it.</small>			
<small>(Enter quantities of schedules attached)</small>			

Guidance for recipients

This safety Certificate has been issued to confirm that the electrical installation work to which it relates has been designed, constructed and inspected and tested in a cordance with British Standard 7671 (The IEE Wiring Regulations).

You should have received an original Certificate and the contractor should have retained a duplicate Certificate. If you were the person ordering the work, but not the user of the installation, you should pass this Certificate, or a full copy of it including the schedules, immediately to the user.

The 'original' Certificate should be retained in a safe place and be shown to any person inspecting or undertaking further work on the electrical installation in the future. If you later vacate the property, this Certificate will demonstrate to the new owner that the electrical installation complied with the requirements of British Standard 7671 at the time the Certificate was issued. The Construction (Design and Management) Regulations require that for a project covered by those Regulations, a copy of this Certificate, together with schedules is included in the project health and safety documentation.

For safety reasons, the electrical installation will need to be inspected at appropriate intervals by a competent person. The maximum time interval recommended before the next inspection is stated on Page 1 under "Next Inspection".

This Certificate is intended to be issued only for a new electrical installation or for new work associated with an alteration or addition to an existing installation. It should not have been issued for the inspection of an existing electrical installation. A "Periodic Inspection Report" should be issued for such a periodic inspection. The Certificate is only valid if a Schedule of Inspections and Schedule of Test Result are appended.

Schedule of inspections

Methods of protection against electric shock	Prevention of mutual detrimental influence
(a) Protection against both direct and indirect contact:	<input type="checkbox"/> (a) Proximity of non-electrical services and other influences
<input type="checkbox"/> (i) SELV (note 1)	<input type="checkbox"/> (b) Segregation of band I and band II circuits or band II insulation used
<input type="checkbox"/> (ii) Limitation of discharge of energy	<input type="checkbox"/> (c) Segregation of safety circuits
(b) Protection against direct contact: (note 2)	Identification
<input type="checkbox"/> (i) Insulation of live parts	<input type="checkbox"/> (a) Presence of diagrams, instructions, circuit charts and similar information
<input type="checkbox"/> (ii) Barriers or enclosures	<input type="checkbox"/> (b) Presence of danger notices and other warning notices
<input type="checkbox"/> (iii) Obstacles (note 3)	<input type="checkbox"/> (c) Labelling of protective devices, switches and terminals
<input type="checkbox"/> (iv) Placing out of reach (note 4)	<input type="checkbox"/> (d) Identification of conductors
<input type="checkbox"/> (v) PELV	Cables and conductors
<input type="checkbox"/> (vi) Presence of RCD for supplementary protection	<input type="checkbox"/> (a) Routing of cables in prescribed zones or within mechanical protection
(c) Protection against indirect contact:	<input type="checkbox"/> (b) Connection of conductors
(i) EEBADS including:	<input type="checkbox"/> (c) Erection methods
<input type="checkbox"/> Presence of earthing conductor	<input type="checkbox"/> (d) Selection of conductors for current-carrying capacity and voltage drop
<input type="checkbox"/> Presence of circuit protective conductors	<input type="checkbox"/> (e) Presence of fire barriers, suitable seals and protection against thermal effects
<input type="checkbox"/> Presence of main equipotential bonding conductors	General
<input type="checkbox"/> Presence of supplementary equipotential bonding conductors	<input type="checkbox"/> (a) Presence and correct location of appropriate devices for isolation and switching
<input type="checkbox"/> Presence of earthing arrangements for combined protective and functional purposes	<input type="checkbox"/> (b) Adequacy of access to switchgear and other equipment
<input type="checkbox"/> Presence of adequate arrangements for alternative source(s), where applicable	<input type="checkbox"/> (c) Particular protective measures for special installations and locations
<input type="checkbox"/> Presence of residual current device(s)	<input type="checkbox"/> (d) Connection of single-pole devices for protection or switching in phase conductors only
<input type="checkbox"/> (ii) Use of Class II equipment or equivalent insulation (note 5)	<input type="checkbox"/> (e) Correct connection of accessories and equipment
<input type="checkbox"/> Non-conducting location: (note 6)	<input type="checkbox"/> (f) Presence of undervoltage protective devices
<input type="checkbox"/> Absence of protective conductors	<input type="checkbox"/> (g) Choice and setting of protective and monitoring devices for protection against indirect contact and/or overcurrent
<input type="checkbox"/> (iv) Earth-free equipotential bonding: (note 7)	<input type="checkbox"/> (h) Selection of equipment and protective measures appropriate to external influences
<input type="checkbox"/> Presence of earth-free equipotential bonding conductors	<input type="checkbox"/> (i) Selection of appropriate functional switching devices
<input type="checkbox"/> (v) Electrical separation (note 8)	
Inspected by _____	Date _____

Notes:

- ✓ to indicate an inspection has been carried out and the result is satisfactory
 - X to indicate an inspection has been carried out and the result was unsatisfactory
 - N/A to indicate the inspection is not applicable
 - LIM to indicate that, exceptionally, a limitation agreed with the person ordering the work prevented the inspection or test being carried out
- SELV An extra-low voltage system which is electrically separated from Earth and from other systems. The particular requirements of the Regulations must be checked (see Regulations 411-02 and 471-02)
 - Method of protection against direct contact - will include measurement of distances where appropriate
 - Obstacles - only adopted in special circumstances (see Regulations 412-04 and 471-06)
 - Placing out of reach - only adopted in special circumstances (see Regulations 412-05 and 471-07)
 - Use of Class II equipment - infrequently adopted and only when the installation is to be supervised (see Regulations 413-03 and 471-09)
 - Non-conducting locations - not applicable in domestic premises and requiring special precautions (see Regulations 413-04 and 471-10)
 - Earth-free local equipotential bonding - not applicable in domestic premises, only used in special circumstances (see Regulations 413-05 and 471-11)
 - Electrical separation (see Regulations 413-06 and 471-12)

Part 2: PV system - commissioning test sheets - Sheet 2 (array test) (as in draft IEC)

PV Array Test Report - d.c. circuits

Report reference No:	Contractors name and address
Installation address	
Test date	Signature
Description of work under test	Test instrument(s)

String		1	2	3	4	n
Array	Module					
	Quantity					
Array parameters	$V_{oc(stc)}$					
	$I_{sc(stc)}$					
Protective Device	Type					
	Rating (A)					
	d.c. Rating (V)					
	Capacity (kA)					
Wiring	Type					
	Phase (mm ²)					
	Earth (mm ²)					
String test Test method: Annex-2	Voc (V)					
	Isc (A)					
	Sun					
Polarity check						
Earth continuity (where fitted)						
Connected to inverter (serial No.)						
Array insulation Resistance Ref IEC 60364-713-04 Test method: Annex-1	Test voltage (V)					
	Pos – Earth (M Ω)					
	Neg – Earth (M Ω)					
Comments						

Field insulation test procedure

Safety:

- Read and make sure you understand this procedure before you start any work.
- Insulation testing is an electric shock hazard - use caution when performing the testing.
- Do not perform the test before you have received practical training.
- Limit the access to the working area.
- Do not touch and take measures to prevent any other persons to touch any metallic surface with any part of your body when performing the insulation test.
- Do not touch and take measures to prevent any other persons to touch the back of the module/laminate or the module/laminate terminals with any part of your body when performing the insulation test.
- Whenever the Insulation test device is energised there is voltage on the testing area. The equipment is to have to have automatic auto-discharge capability.

NOTE REGARDING TEST METHOD

- Two test methods are possible:
 - a) Test between Array Negative and Earth followed by a test between Array Positive and Earth
 - b) Test between Earth and short-circuited Array Positive & Negative
- Where the structure/frame is bonded to earth, the earth connection may be to any suitable earth connection or to the array frame (where the array frame is utilised, ensure a good contact and that there is continuity over the whole metallic frame).
- For systems where the array frame is not bonded to earth (eg where there is a class II installation) a commissioning engineer may choose to do two tests: i) between Array cables and Earth and an additional test ii) between Array cables and Frame.
- For Arrays that have no accessible conductive parts (eg PV roof tiles) the test should be between Array cables and Building Earth

Test Zone Preparation:

- 1) Limit access to non-authorized personnel.
- 2) Isolate the PV array from the inverter (typically at the array switch disconnecter)
- 3) Disconnect any piece of equipment that could have impact on the insulation measurement (i.e. overvoltage protection) in the junction or combiner boxes.

Equipment Required:

- Insulation resistance test device
- Insulation gloves
- Goggles.
- Safety boots.
- short-circuit box (if required)

Procedure

- 1) The test should be repeated for each Array as minimum. It is also possible to test individual strings if required.
- 2) Wear the safety shoes, gloves and goggles.
- 3) Where the test is to be undertaken between Earth and short-circuited Array positive and Array negative cables - short-circuit the cables with an appropriate short-circuit junction box.
- 4) Connect one lead from the Insulation Resistance test device to the array cable(s) as per the NOTE above.
- 5) Connect the other lead from the Insulation Resistance device to Earth as per NOTE above
- 6) Secure all the test leads (eg with cable ties).
- 7) Follow Insulation Resistance Test Device instructions to ensure the test voltage is according to table 1 and readings in M Ohms.
- 8) Follow Insulation Resistance Test Device instructions to perform the test.
- 9) Ensure system is de-energised before removing test cables or touching any conductive parts.

Table 1

Test method	System Voltage (Voc stc x 1.25)	Test voltage	Minimum Impedance
Array positive & negative shorted together	120V	250V	0.25 MΩ
	<600V	500V	0.5MΩ
	<1000V	1000V	1 MΩ
Separate tests to Array positive and Array negative	120V	250V	0.25 MΩ
	<600V	500 - Voc stc (min. 100V) **	0.5MΩ
	<1000V	1000 - Voc stc (min. 100V) **	1 MΩ

** Test voltage adjusted to prevent peak voltage exceeding module or cable rating

FURTHER READING

- **BS 7671: 2001 'Requirements for Electrical Installations, IEE Wiring Regulations',** Sixteenth Edition (incorporating Amendments), ISBN: 0 86341 373 0, www.iee.org/publish/books/WireAssoc
- **IEE Guidance Note 7 - Special Locations,** (2nd Edition), ISBN 0 85296 995 3, www.iee.org/publish/books/WireAssoc
Note: IEE Guidance Note 7 - Special Locations, Chapter 12 covers 'Solar photovoltaic (PV) power supply systems' as a 'special location' as defined in IEE Regs. The guidance is based on IEC 60364-7-712: 'Requirements for special installations or locations – Solar photovoltaic (PV) power systems'.
- **Part P (Electrical safety) - Building Regulations,** www.odpm.gov.uk/index.asp?id=1130906
Note: From 1st January 2005, people undertaking electrical work in homes and gardens in England and Wales have had to follow new rules in Building Regulations. Virtually all domestic PV installations will fall under the scope of Part P. There are two routes to comply with the requirements of Part P:
 - Notify the relevant Building Control department before starting the work
 - The contractor registers under a Competent Person Scheme (as approved by the office of the deputy prime minister)
 Note: An electronic version of the form is available at the Local Authority Building Control (LABC) website [www.link2content.co.uk/uploads/buildingnotice%202005%20unprotected\(1\).doc](http://www.link2content.co.uk/uploads/buildingnotice%202005%20unprotected(1).doc), and it can be submitted using their 'Submit-a-Plan' scheme www.labc-services.co.uk/buildingregs/default.asp.
- **Engineering Recommendation G83/1: Sept 2003, 'Recommendations for the connection of Small-scale Embedded Generators (up to 16A per phase) in parallel with Public Low-Voltage Distribution Networks',** (Energy Networks Association, 2003), www.energynetworks.org/dg01.asp
Note: This simplified connection route applies to 'type tested' inverters for systems up to about 5kVA per phase (see sect 2.4.1). Prior-notification of the Distribution Network Operator (DNO) is not required for 'single' installations, but is required for 'multiple' single phase installations. It refers to the **Electricity Safety, Quality and Continuity Regulations (ESQCR), 2002. Draft prEN 50438 'Requirements for the connection of micro-cogenerators in parallel with public low-voltage distribution networks'** is a European version, which once issued, will also cover systems up to 16A.
- **Engineering Recommendation G59/1, 'Recommendations for the connection of Embedded Generating Plant to the Regional Electricity Companies' Distribution Systems',** (Electricity Association, 1991), www.energynetworks.org/dg01.asp
Note: This is the Electricity Industry Recommendation for connection of generators. It is applicable if the inverter is not covered under G83/1.
- **IEC 61215 Building Control Approval 'Crystalline silicon terrestrial photovoltaic (PV) modules – Design qualification and type approval',** www.iec.ch
Note: This is the International standard for crystalline PV. It specifies requirements for the design qualification and type approval of terrestrial photovoltaic modules suitable for long-term operation in general open-air climates, as defined in IEC 60721-2-1. It

determines the electrical and thermal characteristics of the module and shows, as far as possible, that the module is capable of withstanding prolonged exposure in certain climates.

- **IEC 61646 'Thin film terrestrial photovoltaic (PV) modules – Design qualification and type approval'**, www.iec.ch

Note: This is the International standard for thin film PV. It specifies requirements for the design qualification and type approval of terrestrial thin-film photovoltaic modules suitable for long-term operation in moderate open-air climates.

- **IEC 61730-1 'Photovoltaic (PV) module safety qualification - Part 1: Requirements for construction & IEC 61730-2 'Photovoltaic (PV) module safety qualification - Part 2: Requirements for testing'**, www.iec.ch

Note: Part 1 is Fundamental construction requirements, Part 2 is Testing requirements. These two international standards specify requirements for photovoltaic modules in order to provide safe electrical and mechanical operation during their expected lifetime. They address the prevention of electrical shock, fire hazards, and personal injury due to mechanical and environmental stresses. Pertains to the particular requirements of construction and is to be used in conjunction with **IEC 61215** or **IEC 61646**.

- **IEC61215 Building Control Approval**, www.odpm.gov.uk/index.asp?id=1130474, www.labc-services.co.uk/buildingregs/default.asp

Note: For 'integrated products' in the UK where the PV forms part of the building envelope (eg PV roof tiles), proof of compliance with relevant Building Regulations may be required by the local Building Control Inspector, eg compliance to:

- Fire resistance standards (eg BS 476- part 3)
- Relevant wind uplift and weatherproofing standards (eg **BS 6399**, **BS 5534**).

See also **BRE Digest 489 & 495** below which are specific to PV.

- **PPS22 'Planning Policy Statement 22: Renewable Energy**, ISBN 0 11 753924 4, 2004, www.odpm.gov.uk/index.asp?id=1143908

Note: UK Planning Consent (if required). PPS22 replaces **UK Planning Policy Guidance note (PPG)22**. It sets out the Government's planning policies for renewable energy, which planning authorities should have regard to when preparing local development documents and when taking planning decisions.

Also see '**Planning for Renewable Energy; A companion Guide to PPS22**', which provides additional guidance for PV in Technical Annex 6 Active Solar (Photovoltaics), ISBN 1 85112 7542.

- **BRE Digest 489 – 'Wind loads on roof-based photovoltaic systems'**, ISBN 1 86081 713 0, 2004, www.brebookshop.com

Note: This Digest reviews the wind loading information appropriate for roof-based PV systems and gives recommendations and guidance for the design of roof-based PV systems for wind loads. It covers both PV tiles or slates integrated into pitched roofs and PV modules mounted on or above pitched roofs.

- **BRE Digest 495 – Mechanical installation of roof-mounted photovoltaic systems**, ISBN 1 86081 869 23, 2005, www.brebookshop.com

Note: This Digest gives guidance on installing and using photovoltaic systems on roofs. The guidance refers only to the mechanical installation of roof mounted integrated and stand-off photovoltaic systems; it provides best practice guidance on installation requirements and does not constitute fixing instructions.

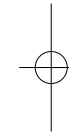
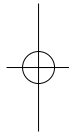



- 1 **'Photovoltaics in Buildings – Safety and the CDM Regulations'**, (BSRIA/DTI Feb 2000, ISBN 0 86022 548 8), www.bsria.co.uk/bookshop/system/index.html
 Note: This covers larger systems, although most of the safety advice is also relevant to small installations that may be exempt from the Regulations. It provides a simple guide to the **Construction Design and Management Regulations 1994 (CDM Regulations)**, with regard to the design, installation, operation, maintenance, decommissioning and disposal of PV installations in buildings. It also provides a commentary on the UK legislative framework with particular reference to CDM Regulations, hazards and risks associated with PV installations, and PV issues that must be addressed in the **Health and Safety Plan and Health and Safety File**.
- 1 **Draft IEC 62446 Ed.1 'Grid connected PV systems – Minimum system documentation, commissioning tests and inspection requirements'**.
 Note: This standard will define the minimum information and documentation required to be handed over to a customer following the installation of a grid connected PV system. This document also describes the minimum commissioning tests, inspection criteria and documentation expected to verify the safe installation and correct operation of the system. This document is not written for AC module systems or systems that utilize energy storage (e.g. batteries) or hybrid systems.
- 1 **Guide CE72 'Installing small wind-powered electricity generating systems'**, Energy Efficiency Best Practice in Housing, 2004
 Note: A companion Guide for small wind systems 500W to 25kW.
- 1 **Draft IEC 62257-7-2 Technical Specification: 'Recommendations for small renewable energy and hybrid systems for rural electrification – Part 7-1: Generators – Photovoltaic arrays'**
 Note: This is a draft Technical Specification not a Standard, but includes much useful guidance and explanation of international best practice for installation of PV systems.
- 1 **BS 6133:1995, 'Code of practice for Safe operation of lead-acid stationary batteries'**
 Note: This includes guidance on design, operation & maintenance of battery systems.
- 1 **BSI PD 6484:1979, 'Commentary on corrosion at bimetallic contacts and its alleviation'**
 Note: This includes guidance on the selection of metals for mechanical design of arrays
- 1 **BS 476 'Fire tests on building materials and structures'**
- 1 **BS 6399 'Loading for buildings. Code of practice.'**
- 1 **BS 5534 'Code of practice for slating and tiling (including shingles)'**
- 1 **BS 3535 'Specification for safety isolating transformers for industrial and domestic purposes'**
- 1 **BS 60947 'Specification for low-voltage switchgear and controlgear'**
- 1 **BS3858 'Specification for binding and identification sleeves for use on electric cables and wires'**
- 1 **PD 6484 'Commentary on corrosion at bimetallic contacts and its alleviation'**

Note: Information on the current Government's Grant scheme '**Low Carbon Buildings Programme**' can be found on the Energy Saving Trust website www.est.org.uk



DTI Sustainable
Energy Programmes

 <p>WARNING dual supply</p>	 <p>Isolate on-site generator at _____ Isolate mains supply at _____</p>	<p>Do not work on this equipment until it is isolated from <u>both</u> mains and <u>on-site</u> generation supplies</p>
---	---	--

Sample Dual Supply Label G83/1