

Model 5223
Triaxial Cable Assembly
Male Both Ends, 3 Lug

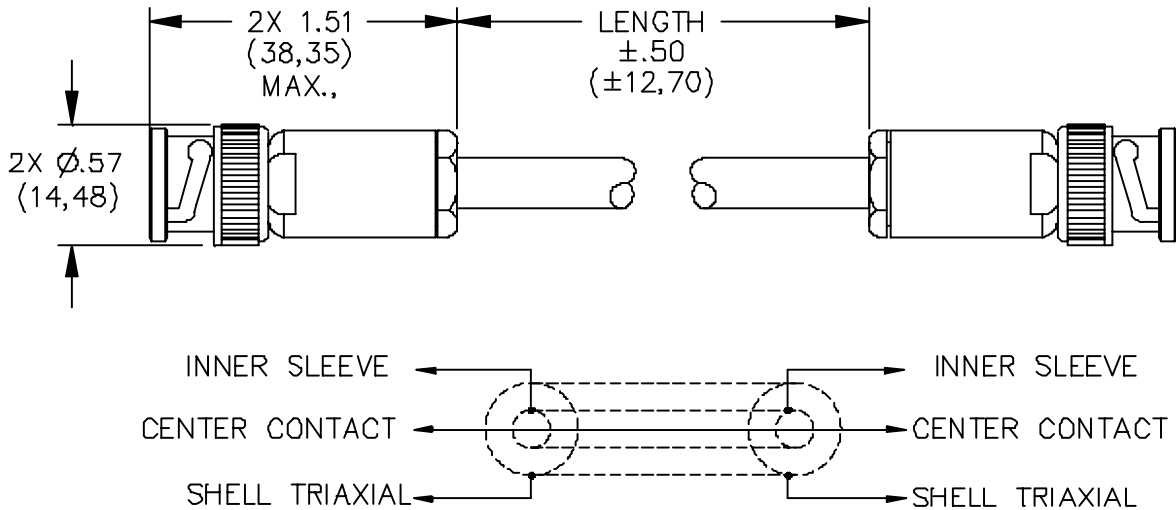

SCHEMATIC

FEATURES:

- Mates to Model #5219
- 2 Shields provided for use in high interference areas
- Lengths other than those specified available upon request.

MATERIALS:

Conn: 1st End-

Triaxial Cable Male: BNC 3 Lug Bayonet Style.

Finish: Body and Fittings – Tarnish Resistant.

Intermediate and Center Contacts: Gold plated per requirements of MIL-C-39012.

Cable: Belden 9222. Triaxial conductors. Nominal Impedance: 50 Ohms. 20 AWG,
Polyethylene dielectric, Shield: Tinned Copper, Jacket: PVC, 6.15 (.242) O.D. Color: Yellow.

Marking: "POMONA 5223"

Conn: 2nd End- Same as first.

RATINGS:

Operating Voltage: 500 VRMS/DC.

Nominal Impedance of Cable: 50 Ohms.

ORDERING INFORMATION: Model 5223-XX

XX=Cable Length, Standard Lengths: 36" (914), 60" (1524), Ordering Example: 5223-60 indicates 60" in length.

All dimensions are in inches. Tolerances (except noted): .xx = ±.02" (.51 mm), .xxx = ± .005" (.127 mm).

All specifications are to the latest revisions. Specifications are subject to change without notice.

Registered trademarks are the property of their respective companies. Made in USA