

Model 5788 Insulated Miniature Alligator Test Clip With 2MM Banana Jack

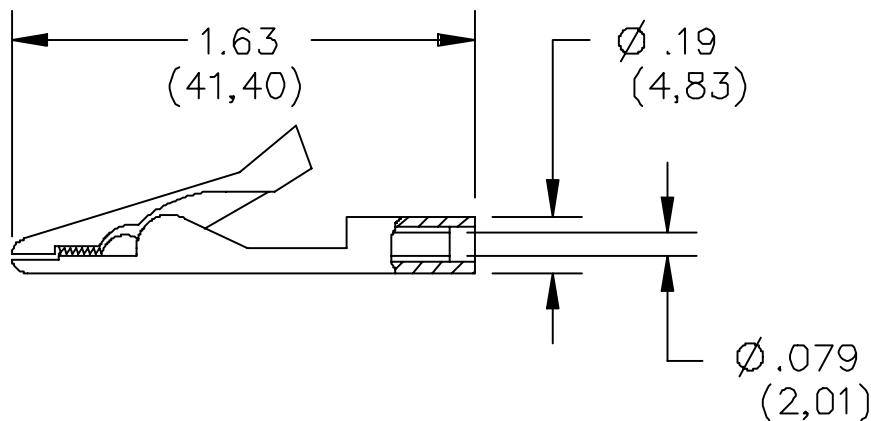

FEATURES:

- Alligator has 6,1mm (.240") max. jaw opening.
- Female receptacle allow quick attachment to 2 mm (.080") non-sheathed plug test leads.
- Overall length of 41,5 mm (1.63") allows alligator access to small access areas.
- Alligator body is insulated for user protection.

MATERIAL:

Body: Copper Alloy, Plated

Insulation: Polypropylene, Colors per part number

RATINGS:

Operating Voltage: 45 VRMS/DC

Operating Temperature: +80°C (+176°F) Max.

ORDERING INFORMATION: Model 5788-*

* = Color, -0 Black, -2 Red

Sold in packs of 10 pieces per color.

All dimensions are in inches. Tolerances (except noted): .xx = ±.02" (.51 mm), .xxx = ±.005" (.127 mm).

All specifications are to the latest revisions. Specifications are subject to change without notice.

Registered trademarks are the property of their respective companies. Made in USA