

Model 3542 Insulated Panel Mount Pin Tip Jack

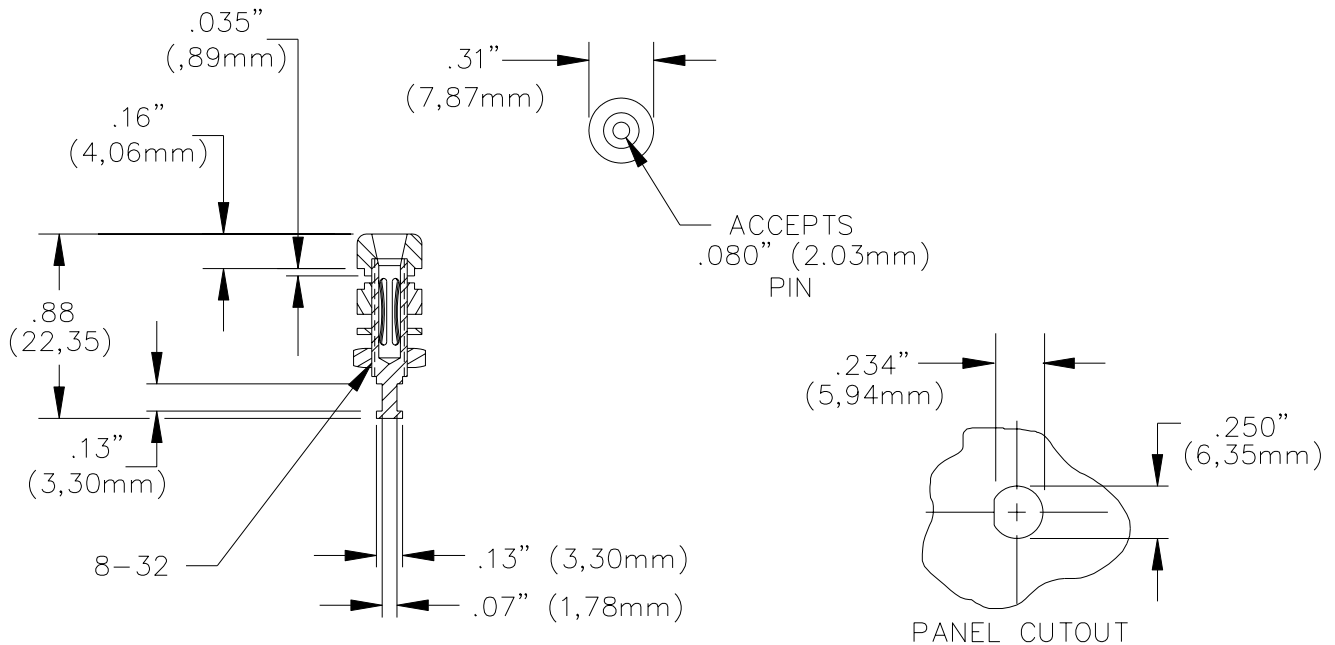

FEATURES:

Accepts .080 pin tip plugs
Mounts in panels up to .250" thick.

MATERIAL:

Insulation – Polycarbonate - Molded to pin tip jack body
Lockwasher, #8 Internal Tooth – Nickel plated Steel
Hex Nut #8-32 – Nickel plated Brass
Pin Tip Jack Body: Gold plated Brass



RATINGS:

Operating Voltage: Hands free usage in controlled voltage environments: 1500 Vrms maximum. *For CE compliance: not intended for hand-held use at voltages above 33 Vrms/70 Vdc.*

Current: 5 Amps

Operating Temperature: +239°F (+115°C). Max.

ORDERING INFORMATION: Model 3542-Color (sold in packages of 10)

Colors =: 0 (Black), 1 (Brown), 2 (Red), 3 (Orange), 4 (Yellow), 5 (Green), 6 (Blue), 7 (Violet), 8 (Gray), 9 (White)

Ordering Example: 3542-2 (Red)

All dimensions are in inches. Tolerances (except noted): .xx = ±.02" (.51 mm), .xxx = ±.005" (.127 mm).

All specifications are to the latest revisions. Specifications are subject to change without notice.

Registered trademarks are the property of their respective companies.

Sales: 800-490-2361 Fax: 888-403-3360 Technical Support: 800-241-2060 (technicalsupport@pomonaest.com)

For "Where to Buy" information, visit the Pomona web site at www.pomonaelectronics.com