

**Betriebsanleitung
Multifunktionales
Leistungsmessgerät**

**Mode d'emploi
Indicateur puissance
multifunction**

**Operating Instructions
Multifunctional
Power Monitor**

SINEAX A 210/A 220



Camille Bauer AG
Aargauerstrasse 7
CH-5610 Wohlen/Switzerland
Telefon +41 56 618 21 11
Telefax +41 56 618 35 35
e-mail: info@camillebauer.com
http://www.camillebauer.com

A 210/A 220 Bd-f-e 151 118-02 02.06



Geräte dürfen nur fachgerecht entsorgt werden!

Sicherheitshinweise

Die Installation und Inbetriebnahme darf nur durch geschultes Personal erfolgen.

Überprüfen Sie vor der Inbetriebnahme, dass:

- die maximalen Werte aller Anschlüsse nicht überschritten werden, siehe Kapitel «Technische Daten»
- die Anschlussleitungen nicht beschädigt und bei der Verdrahtung spannungsfrei sind
- Energierichtung und Phasenfolge stimmen.

Das Gerät muss ausser Betrieb gesetzt werden, wenn ein gefahrloser Betrieb (z.B. sichtbare Beschädigungen) nicht mehr möglich ist. Dabei sind alle Anschlüsse abzuschalten. Das Gerät ist an unser Werk bzw. an eine durch uns autorisierte Service-stelle zu schicken.

Ein Öffnen des Gehäuses bzw. ein Eingriff in das Gerät ist verboten. Das Gerät hat keinen eigenen Netzschalter. Achten Sie darauf, dass beim Einbau ein gekennzeichnete Schalter in der Installation vorhanden ist und dieser vom Benutzer leicht erreicht werden kann.

Bei einem Eingriff in das Gerät erlischt der Garantieanspruch.



Les appareils ne peuvent être éliminés que de façon appropriée!

Consignes de sécurité

L'installation et la mise en service doivent impérativement être faites par du personnel spécialement formé.

Avant la mise en service vérifier les points suivants:

- ne pas dépasser les valeurs maximales de tous les raccordements, voir chapitre «Caractéristiques techniques».
- s'assurer que les lignes raccordées ne soient ni abimées ni sous tension.
- vérifier que le sens d'énergie et la suite des phases soient corrects.

L'appareil doit être mis hors service si un fonctionnement sans danger n'est plus possible (p. ex. suite à un dommage visible). Tous les raccordements doivent être déconnectés. L'appareil doit être retourné en usine resp. à un atelier autorisé pour faire des travaux de service.

Toute intervention et l'ouverture de l'appareil sont interdites. L'appareil ne possède pas d'interrupteur principal propre. Faire attention qu'un interrupteur bien repéré et facilement atteignable par l'utilisateur soit installé.

Toute intervention dans l'appareil entraîne l'extinction de la clause de garantie.



The instruments must only be disposed of in the correct way!

Safety notes

The installation and commissioning should only be carried out by trained personnel.

Check the following points before commissioning:

- that the maximum values for all the connections are not exceeded, see the "Technical data" section,
- that the connection wires are not damaged, and that they are not live during wiring,
- that the power flow direction, and the phase rotation are correct.

The instrument must be taken out of service if safe operation is no longer possible (e.g. visible damage). In this case, all the connections must be switched off. The instrument must be returned to the factory or to an authorized service dealer.

It is forbidden to open the housing and to make modifications to the instrument. The instrument is not equipped with an integrated circuit breaker. During installation check that a labeled switch is installed and that it can easily be reached by the operators.

Unauthorized repair or alteration of the unit invalidates the warranty.

Inhaltsverzeichnis

	Seite
Kurzbeschreibung	2
Technische Daten	2
Wartungshinweis	2
Inbetriebnahme	3
Elektrische Anschlüsse	3
Anschlussarten	3
Anzeige und Bedienung	5
Verfügbare Messdaten	5
Anzeigeebenen	6
Bedienung	6
Programmierung	7
Werkseinstellungen	7
Übersicht der Parameter	7
Kurzanleitung zum Ändern der Parameter	29
Diagramm Programmierung	30
Masszeichnungen	32

Sommaire

	Page
Description brève	11
Caractéristiques techniques	11
Conseil pour la maintenance	11
Mise en service	12
Raccordements électriques	12
Possibilités de raccordement	12
Affichage et utilisation	14
Données de mesure disponibles	14
Niveaux d'affichage	15
Utilisation	15
Programmation	16
Réglage en usine	16
Aperçu des paramètres	16
Instruction abrégée pour modifier les paramètres	29
Diagramme des programmations	30
Croquis d'encombrements	32

Contents

	Page
Brief description	20
Technical data	20
Note of maintenance	20
Commissioning	21
Electrical connections	21
Connection modes	21
Display and operating	23
Available measurement data	23
Display levels	24
Operating	24
Programming	25
Factory default	25
Parameters overview	25
Brief operating instruction for parameter modification	29
Programming charts	30
Dimensional drawings	32

Kurzbeschreibung

Das Gerät A 210 ist ein Einbaugerät im Format 96 x 96 mm, das Gerät A 220 ist ebenfalls ein Einbaugerät im Format 144 x 144 mm. Beide dienen der Analyse von Wechselstromnetzen. Erfasst werden Spannungen, Ströme, Frequenz und Phasenverschiebungen in 1-phasen- bzw. 3-phasen-Netzen. Daraus lassen sich die Größen Wirk-, Blind- und Scheinleistung, Wirk- und Blindenergie, sowie der Leistungsfaktor und der Nullleiterstrom berechnen. In Verbindung mit Strom- und Spannungswandlern, deren Übersetzungsverhältnis zur direkten Anzeige aller Messdaten programmierbar ist, kann das Gerät Messungen in Nieder- und Mittelspannungsnetzen vornehmen. Das Gerät A 210/A 220 dient als Anzeiger mit zwei S0-Ausgängen bzw. Grenzwertmelder-Ausgängen.

Technische Daten

(detaillierte Angaben siehe Datenblatt, downloadbar unter www.camillebauer.com)

Messeingänge \rightarrow

Nennfrequenz:	50, 60 Hz
Eingangsnennspannung:	Leiter - Leiter: 500 V Leiter - N: 290 V
Eingangsnennstrom:	5 A oder 1 A

Zulässige dauernd überhöhte Eingangsgrößen

10 A bei 346 V im Einphasennetz
10 A bei 600 V im Drehstromnetz

Zulässige kurzzeitig überhöhte Eingangsgrößen

Überhöhte Eingangsgröße	Anzahl der Überhöhungen	Dauer der Überhöhungen	Zeitraum zwischen 2 aufeinanderfolgenden Überhöhungen
577 V LN	10	1 s	10 s
100 A	10	1 s	100 s
100 A	5	3 s	5 Min

Messbereiche

U, I, S:	$\leq 120\%$ vom Nennwert
P, Q:	$\leq \pm 120\%$ vom Nennwert
F:	45 bis 65 Hz
$\cos\varphi$:	± 1

Impuls-/Grenzwertausgänge \rightarrow

Die beiden digitalen Ausgänge arbeiten je nach eingestellter Funktion entweder als Impulsausgang für Wirk- bzw. Blindenergie oder als Grenzwertmelder.

Die Ausgänge sind passiv und von allen anderen Kreisen durch Optokoppler galvanisch getrennt. Sie sind für die Ansteuerung von Tarifgeräten (S0-Norm DIN 43 864), oder von 24 V-Relais geeignet.

U_{ext}	≤ 40 V DC (OFF: Leckstrom $\leq 0,1$ mA)
I_L	≤ 150 mA (ON: Klemmenspannung $\leq 1,2$ V)

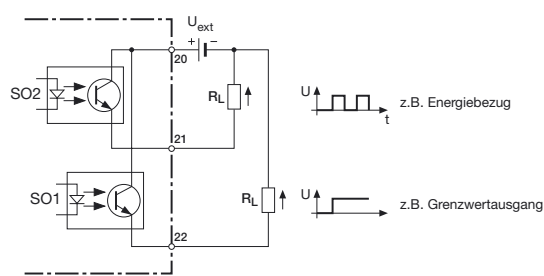

Grenzwertausgänge

Die Messgrößen können frei zugeordnet werden.

Impulsausgänge

Es können Wirk- und Blindenergie-Impulse zur Ansteuerung von elektronischen und elektromechanischen Zählern erzeugt werden.

Hilfsenergie* \rightarrow \bigcirc

DC-, AC-Netzteil 45 bis 400 Hz
85 bis 253 V AC/DC oder 20 bis 70 V AC/DC
Leistungsaufnahme: < 3 VA (ohne Erweiterungsmodul)

* Bei DC-Hilfsenergie > 125 V muss im Hilfsenergiekreis eine externe Sicherung vorgesehen werden.

Referenzbedingungen nach IEC 688 bzw. EN 60 688

Sinus 50 - 60 Hz, 15 - 30°, Anwendungsgruppe II

Messgenauigkeit (bezogen auf Nennwert)

Strom, Spannung	$\pm 0,5\%$
Leistung	$\pm 1,0\%$
Powerfaktor	$\pm 1,0\%$
Energie	$\pm 1,0\%$
Frequenz	$\pm 0,02$ Hz (absolut)

Umgebungsbedingungen

Betriebstemperatur:	-10 bis +55 °C
Lagertemperatur:	-25 bis +70 °C
Relative Feuchtigkeit:	$\leq 75\%$
Betriebshöhe:	2000 m max.
Nur in Innenräumen zu verwenden	

Sicherheit

Schutzklasse: II (Spannungseingänge mit Schutzimpedanz)

Messkategorie: III
Verschmutzungsgrad: 2
Bemessungsspannung: 300 V
Prüfspannungen: Zwischen Stromeingängen, Hilfsenergie, Digitalausgängen, Klemmen des aufgesetzten Steckmoduls: 3700 V / 50 Hz / 1 Min.

An Spannungseingängen: 4,25 kV 1,2/50 μ s

Modulanschluss: Die rückseitige Stiftleiste ist via Schutzimpedanz mit den Spannungseingängen verbunden. Es dürfen nur die zulässigen Module aufgesteckt werden!

Berührungsschutz: Front IP 66, Klemmen IP 20

Wartungshinweis

Das Leistungsmessgerät ist wartungsfrei.

Anzeige

Die Anzeige erfolgt 3-stellig bzw. 4-stellig (Frequenz) und rechtsbündig, mit Ausnahme der Energiewerte, deren Umfang 8 Stellen beträgt. Die linke 7-Segmentanzeige dient der Darstellung von Vorzeichen oder Abkürzungen.

Abkürzungen:

\square	Maximalwert
\square	Minimalwert
\square	Mittelwert
\square	max. Mittelwert
\square	Minimalwert für Powerfaktor; es wird der schlechteste der 3 Werte von P1, P2 und P3 angezeigt
\square	Nullleiterstrom
\square	Induktiv
\square	kapazitiv
\square	incoming, Bezug
\square	outgoing, Abgabe
\square	Intervall Wirkleistung
\square	Intervall Blindleistung
\square	Intervall Scheinleistung
\square	letztes Intervall; t-0
$\square, \square 2 \dots$	vorletztes Intervall; t-1, -2, -3, -4
\square	Overload, Überbereichsanzeige
Σ	Systemwert
Δ	Dreiecksspannung

Energiezähler

- .H Hochtarif
- .L Niedertarif

	Intervall 0	Intervall 1	Intervall 2	Intervall 3	Intervall 4
Aktuelle Zeit t	t-0	t-1	t-2	t-3	t-4

Nullpunktunterdrückung

PF bzw. $\cos\phi$:

Anzeige ---, wenn $S_x < 0,2\% S_{nenn}$

Ströme:

Anzeige 0, wenn $I_x < 0,1\% I_{nenn}$

Inbetriebnahme

Das Leistungsmessgerät kann durch Einschalten der Hilfsenergie in Betrieb genommen werden. Es erscheinen nacheinander folgende Anzeigen:

- Segmenttests:** Alle Segmente der Anzeige und alle LED's leuchten für 2 s.
- Softwareversion:** z.B. A 210 1.04
- Die 3 **Strangspannungen** bei der Erstinbetriebnahme.

Hilfsenergieausfall

Bei einem Hilfsenergieausfall bleiben alle programmierten Werte erhalten.

Nach dem Wiederanlegen der Hilfsenergie wird der zuletzt gewählte **Modus** angezeigt.

Elektrische Anschlüsse

(abgebildet ist der SINEAX A 210. Die Anschlüsse sind jedoch beim SINEAX A 220 identisch).

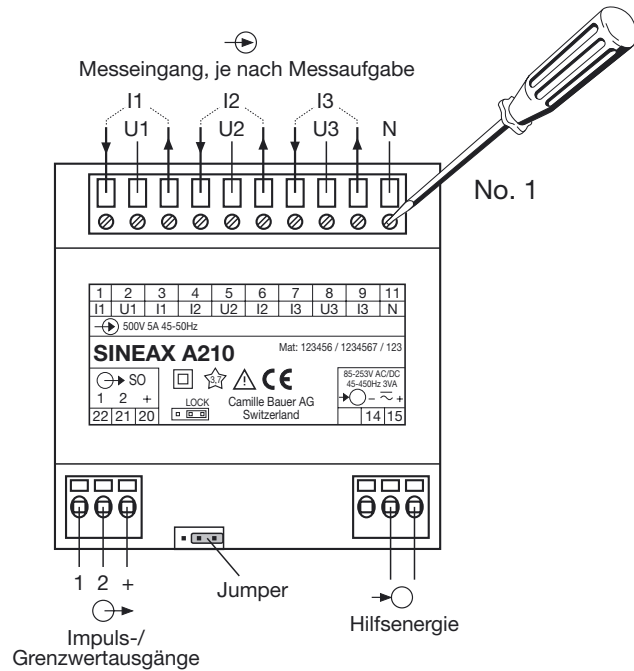

Anschlussarten

Netzformen/ Anwendung	Klemmenbelegung
Einphasen-Wechselstromnetz 	
Dreileiter-Drehstromnetz gleichbelastet I: L1 	
Dreileiter-Drehstromnetz ungleichbelastet 	

Bei Strommessung über L2 bzw. L3, Spannungsanschluss nach folgender Tabelle vornehmen:

Stromwandler	Klemmen	2	5	8
L2	1	3	L2	L3
L3	1	3	L3	L1

Netzformen/
Anwendung

Klemmenbelegung

Vierleiter-
Drehstromnetz
gleichbelastet
I: L1

4068

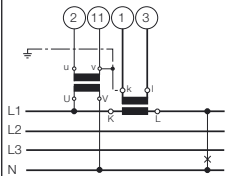
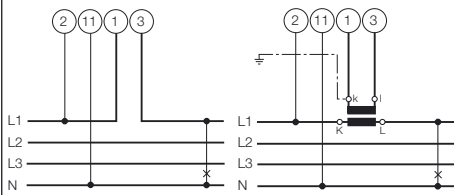

Bei Strommessung über L2 bzw. L3,
Spannungsanschluss nach folgender Tabelle
vornehmen:

Stromwandler	Klemmen	2	11
L2	1	3	L2
L3	1	3	L3

Vierleiter-
Drehstromnetz
ungleich-
belastet

4068

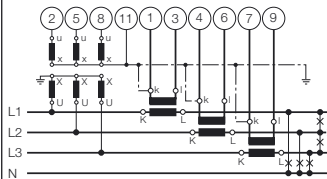
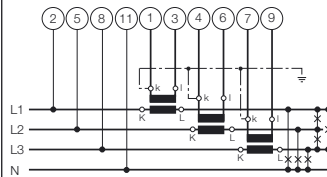
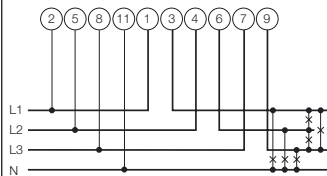

3 einpolig isolierte Spannungswandler im
Hochspannungsnetz

Anzeige und Bedienung

(abgebildet ist der SINEAX A 210. Die Anzeige und die Bedienung sind jedoch beim SINEAX A 220 identisch.)

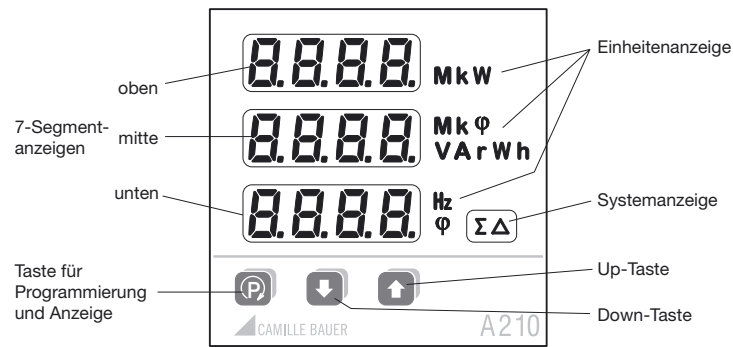

Powerfaktor cosφ 4-Quadranten-darstellung

Verfügbare Messdaten	Beispiel Anzeige oben	Beispiel Anzeige mitte	Beispiel Anzeige unten	Einheiten-anzeige	System-anzeige
Phasenspannungen U1, U2, U3	230	231	229	V	
Maximalwerte U1 _{max.} , U2 _{max.} , U3 _{max.}	235	236	231	V	
Minimalwerte U1 _{min.} , U2 _{min.} , U3 _{min.}	227	226	225	V	
Dreieckspannungen U12, U23, U31	400	402	398	V	Δ
Maximalwerte U12 _{max.} , U23 _{max.} , U31 _{max.}	405	406	403	V	Δ
Minimalwerte U12 _{min.} , U23 _{min.} , U31 _{min.}	395	397	396	V	Δ
Phasenströme I1, I2, I3	2.35	2.37	2.34	A	
Maximalwerte I1 _{max.} , I2 _{max.} , I3 _{max.}	2.39	2.40	2.38	A	
Mittelwert I1 _{avg.} , I2 _{avg.} , I3 _{avg.} (Bimetall-15 Min.)	2.04	2.05	2.07	A	
Max. Mittelwert I1 _{avgmax.} , I2 _{avgmax.} , I3 _{avgmax.} (Schleppzeiger-15 Min.)	2.07	2.05	2.04	A	
Nullleiterstrom IN	0.0	0.45		A	
Wirkleistungen P1, P2, P3	56.1	56.2	56.5	kW	
Maximalwerte P1 _{max.} , P2 _{max.} , P3 _{max.}	60.5	60.4	60.3	kW	
Wirkleistung System P		125		kW	Σ
Maximalwert P _{max.}		239		kW	Σ
Blindleistungen Q1, Q2, Q3	1.24	1.23	1.22	VAr	
Maximalwerte Q1 _{max.} , Q2 _{max.} , Q3 _{max.}	1.51	1.52	1.54	VAr	
Blindleistung System Q		1.54		VAr	Σ
Maximalwert Q _{max.}		2.31		VAr	Σ
Scheinleistungen S1, S2, S3	2.56	2.58	2.60	VA	
Maximalwerte S1 _{max.} , S2 _{max.} , S3 _{max.}	3.43	3.44	3.67	VA	
Scheinleistung System S		5.33		VA	
Maximalwert S _{max.}		6.23		VA	Σ
Powerfaktor PF1, cosφ	0.87	0.87	0.87	φ	
Powerfaktor PF2, cosφ	0.88	0.88	0.88	φ	
Powerfaktor PF3, cosφ	0.89	0.89	0.89	φ	
Powerfaktor System PF, cosφ	0.88	0.88	0.88	φ	Σ
Minimalwert Powerfaktor induktiv	0.76	0.76	0.76	φ	Σ
Minimalwert Powerfaktor kapazitiv	0.84	0.84	0.84	φ	Σ
Frequenz, F			49.99	Hz	
Wirkenergie Bezug EP Hochtarif	4589	2356	0.00	kWh	Σ
Wirkenergie Bezug EP Niedertarif *)	1234	5678	0.00	kWh	Σ
Wirkenergie Abgabe EP Hochtarif	4589	2356	0.00	kWh	Σ
Wirkenergie Abgabe EP Niedertarif *)	1234	5678	0.00	kWh	Σ
Blindenergie induktiv EQ Hochtarif	9876	5432	0.00	kVarh	Σ
Blindenergie induktiv EQ Niedertarif *)	1234	9876	0.00	kVarh	Σ
Blindenergie kapazitiv EQ Hochtarif	9876	5432	0.00	kVarh	Σ
Blindenergie kapazitiv EQ Niedertarif *)	1234	9876	0.00	kVarh	Σ
5 Wirkleistungs-Intervalle Pint0, Pint1, ...	0.00	234	0.00	kW	Σ
5 Blindleistungs-Intervalle Qint0, Qint1, ...	0.00	123	0.00	VAr	Σ
5 Scheinleistungs-Intervalle Sint0, Sint1, ...	0.00	10.1	0.00	VA	Σ

*) Tarumschaltung nur mit Digitaleingang möglich (optionales Erweiterungsmodul)

Berechnung der Messgrößen

Die Berechnung der Messgrößen erfolgt nach DIN 40 110, mit Ausnahme der Blindleistung. Der SINEAX A 210/A 220 berechnet diese mit Vorzeichen.

Messumformer bzw. Anzeiger können im gleichen Netz u.U. verschiedene Werte für die Blindleistung anzeigen.

Der Grund sind die unterschiedlichen Berechnungsarten.

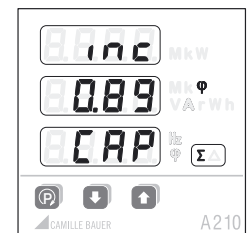

System

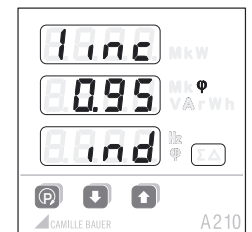

Phase 1

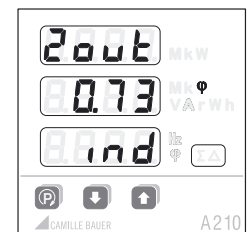

Phase 2

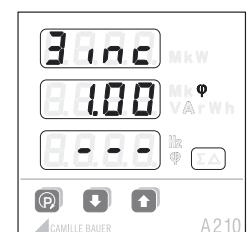

Phase 3

Anzeigebenen

Innerhalb einer Ebene (1, 2, 3 ...) können Sie mit der **P** Taste die 3 Anzeigen in den nächsten Modus (a, b, c, ...) umschalten. Am Ende des Modus beginnt die Anzeige wieder mit dem Modus a.

In die nächste Ebene wechseln Sie durch kurzes Drücken der **↑** und **↓** Tasten.

Vierleiter ungleichbelastet

		a	b	c	d	e	f	
 	1	U1 U2 U3	U1 _{max.} U2 _{max.} U3 _{max.}	U1 _{min.} U2 _{min.} U3 _{min.}	U12 U23 U31	U12 _{max.} U23 _{max.} U31 _{max.}	U12 _{min.} U23 _{min.} U31 _{min.}	
	2	I1 I2 I3	I1 _{max.} I2 _{max.} I3 _{max.}	I1 _{avg.} I2 _{avg.} I3 _{avg.}	I1 _{avgmax.} I2 _{avgmax.} I3 _{avgmax.}	IN	IN _{max.}	
	3	P1 P2 P3	P1 _{max.} P2 _{max.} P3 _{max.}	P	P _{max.}			
	4	Q1 Q2 Q3	Q1 _{max.} Q2 _{max.} Q3 _{max.}	Q	Q _{max.}			
	5	S1 S2 S3	S1 _{max.} S2 _{max.} S3 _{max.}	S	S _{max.}			
	6	PF1	PF2	PF3	PF	PF _{minind}	PF _{mincap}	
	7	F						
	8	EP inc HT ¹	EP inc LT ²	EP out HT ¹	EP out LT ²			
	9	EQ ind HT ¹	EQ ind LT ²	EQ cap HT ¹	EQ cap LT ²			
	10	P Q PF	P S F					
	11	Pint0	Pint1	Pint2	Pint3	Pint4		
	12	Qint0	Qint1	Qint2	Qint3	Qint4		
	13	Sint0	Sint1	Sint2	Sint3	Sint4		

Einphasig, Dreileiter gleichbelastet, Vierleiter gleichbelastet

		a	b	c	d	e
 	1	U	U _{max.}	U _{min.}		
	2	I	I _{max.}	I _{avg.}	I _{avgmax.}	
	3	P	P _{max.}			
	4	Q	Q _{max.}			
	5	S	S _{max.}			
	6	PF	PF _{minind}	PF _{mincap}		
	7	F				
	8	EP inc HT ¹	EP inc NT ²	EP out HT ¹	EP out NT ²	
	9	EQ ind HT ¹	EQ ind NT ²	EQ cap HT ¹	EQ cap NT ²	
	10	P Q PF	P S F			
	11	Pint0	Pint1	Pint2	Pint3	Pint4
	12	Qint0	Qint1	Qint2	Qint3	Qint4
	13	Sint0	Sint1	Sint2	Sint3	Sint4

Bedienung

Helligkeit

13 Stufen: Längeres Drücken der Tasten **↓** (dunkler) **↑** (heller).

Löschen / Clear

Gleichzeitiges Drücken der Tasten **↓** **↑** löscht die min- bzw. max-Werte bzw. die Energiewerte der angezeigten Größen.

Verriegelung

Die Rückstellfunktion für die Energiezähler kann gesperrt werden, indem der Jumper auf der Geräterückseite in Position LOCK gebracht wird.

Dreileiter ungleichbelastet

		a	b	c	d	e
 	1	U12 U23 U31	U12 _{max.} U23 _{max.} U31 _{max.}	U12 _{min.} U23 _{min.} U31 _{min.}		
	2	I1 I2 I3	I1 _{max.} I2 _{max.} I3 _{max.}	I1 _{avg.} I2 _{avg.} I3 _{avg.}	I1 _{avgmax.} I2 _{avgmax.} I3 _{avgmax.}	
	3	P	P _{max.}			
	4	Q	Q _{max.}			
	5	S	S _{max.}			
	6	PF	PF _{minind}	PF _{mincap}		
	7	F				
	8	EP inc HT ¹	EP inc LT ²	EP out HT ¹	EP out LT ²	
	9	EQ ind HT ¹	EQ ind LT ²	EQ cap HT ¹	EQ cap LT ²	
	10	P Q PF	P S F			
	11	Pint0	Pint1	Pint2	Pint3	Pint4
	12	Qint0	Qint1	Qint2	Qint3	Qint4
	13	Sint0	Sint1	Sint2	Sint3	Sint4

¹ HT = Hochtarif

² LT = Niedertarif

Programmierung

Alle Parameter lassen sich jederzeit anzeigen. Für Veränderungen muss aber der Jumper auf der Rückseite des Gerätes gezogen sein (Stellung nicht auf LOCK).

Die folgende Tabelle zeigt alle Parameter mit ihren einstellbaren Bereichen bzw. den möglichen Selektionen. Die schwarzen Nummern geben einen Querverweis auf die entsprechende Stelle im Diagramm auf Seite 30.

Von der Messwert-Anzeige gelangt man durch langes Drücken der Taste **(P)** in die Menü-Ebene.

Danach kann durch weiteres kurzes Drücken der Taste **(P)** der gewünschte Menüpunkt angewählt werden.

Mit der Taste **(↓)** gelangt man in die Parameter-Ebene, wo der gewünschte Parameter angezeigt werden kann.

Durch kurzes Drücken der Taste **(P)** beginnt das wählbare Element zu blinken.

Der blinkende Inhalt kann mit den Tasten **(↓)** / **(↑)** verändert werden.

Die Parameter- oder Menü-Ebene wird durch langes Drücken der Taste **(P)** wieder verlassen.

Die Einstellungen bleiben danach auch bei Versorgungsausfall gespeichert.

Hinweise:

Die Anschlussart und die Wandlerfaktoren müssen immer zuerst eingestellt werden, weil die Messwertanzeigen, Grenzwerteinstellungen etc. davon abhängig sind.

Die Programmierung kann auch über ein Erweiterungsmodul (Option) verändert werden.

Sperren der Programmierung

Jumper in Stellung LOCK.

Die Programmierung aller Werte ist blockiert.

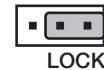

Werkzeugeinstellungen

Helligkeit: (mittlerer Wert)
 Grenzwert / S01: Off
 Grenzwert / S02: Off
 Wandlerverhältnis: 1 : 1
 Jumper: Nicht in Stellung LOCK
 Anschlussart: Vierleiter ungleichbelastet
 Synchron-Intervall: 15 min.

Übersicht der Parameter

Nr.	Anzeige oben Anzeige mitte	Anzeige unten (Auswahl, * = Default)	Bedeutung	Hinweis
1	0000 TYPE		Anschlussart	
		4000 *	Vierleiternetz ungleich belastet	(4 lines unbalanced)
		3000	Dreileiternetz ungleich belastet	(3 lines unbalanced)
		4000	Vierleiternetz gleich belastet	(4 lines balanced)
		3000	Dreileiternetz gleich belastet	(3 lines balanced)
		0000	Einphasennetz	(1 line)
2	0000 0000	0000	Belastungsart bei NetZRückspeisung: mathematisch	4-Quadrantenanzeige Ind-Cap-Ind-Cap
		0000	Belastungsart bei NetZRückspeisung: elektrisch	4-Quadrantenanzeige Ind-Ind-Cap-Cap
3	0000 0000	0.500 kV* 100 V bis 999 kV	Primär-Spannung des externen Wandlers am Spannungseingang (Dreieckspannung)	Zuerst kann eine beliebige 3-stellige Zahl und danach die zugehörige Grösseneinheit in Schritten von Faktor 10 eingegeben werden
4	0000 0000	0.500 v* 100 V bis 999 V	Sekundär-Spannung des externen Wandlers am Spannungseingang (Dreieckspannung)	
5	0000 0000	0.500 A* 1,00 A bis 999 kA	Primär-Strom des externen Wandlers am Stromeingang	
6	0000 0000	0.500 A* 0,1 A bis 9,99 A	Sekundär-Strom des externen Wandlers am Stromeingang	

Nr.	Anzeige oben Anzeige mitte	Anzeige unten (Auswahl, * = Default)	Bedeutung	Hinweis		
7	888.8 / .2 A888		Betriebsart der beiden Digitalausgänge «out.1» und «out.2»	(Mode)		
		888.8 *	Ausgang ausgeschaltet	Ansteuerung via Bus-Schnittstelle bleibt jedoch möglich		
		888.8	Energie-Impuls-Ausgang	Der Ausgang erzeugt Energie-Impulse mit der unter 12 eingestellten Impulsrate. Die auszugebende Zählergrösse kann unter 11 ausgewählt werden.		
		888.8	Alarm-Ausgang	Bei Überschreitung des Grenzwertes 9 wird der Ausgang aktiv (Strom fliesst). Bei Unterschreitung von 10 wird der Ausgang passiv. Die Quelle der überwachten Messgrösse ist in 8 festgelegt.		
8	888.8 / .2 A.888		Quelle der Alarmüberwachung	Diese Auswahl wird angeboten, wenn zuvor die Betriebsart 7 auf ALM gesetzt wurde		
				Line Type		
				'1L', '3Lb', '4Lb'	'3Lu'	'4Lu'
		8.888	Frequenz	●	●	●
		8.888	Nullleiterstrom			●
		5.888	Intervall-Scheinleistung	●	●	●
		9.888	Intervall-Blindleistung	●	●	●
		8.888	Intervall-Wirkleistung	●	●	●
		88.88	Powerfaktor (cos φ)	●	●	○
		5.888	Scheinleistung	●	●	○
		9.888	Blindleistung	●	●	○
		8.888	Wirkleistung	●	●	○
		0.888	Spannung	●		
		0.888 *	Phasenspannung			○
		0.888	Dreieckspannung		○	○
8.880	Phasenstrom Average (Bimetall)	●	○	○		
8.888	Phasenstrom	●	○	○		
			○: 'A.on' = OR-Verknüpfung der Phasengrössen 'A.off' = AND-Verknüpfung der Phasengrössen			
9	888.8 / .2 A.888	888.0 v *	Einschaltgrenze für Alarm	Der maximale Wert richtet sich nach dem möglichen Messbereich und ist abhängig von den gewählten Wandlerfaktoren und Anschlussarten.		
10	888.8 / .2 A.888	882.0 v *	Ausschaltgrenze nach Alarm			

Nr.	Anzeige oben Anzeige mitte	Anzeige unten (Auswahl, * = Default)	Bedeutung	Hinweis
11	0000 / .2 E.500		Quelle des Energiezählers für Impulsausgang	
		0000	Blindenergie kapazitiv Niedertarif	
		0000	Blindenergie kapazitiv Hochtarif	
		0000	Blindenergie induktiv Niedertarif	
		0000	Blindenergie induktiv Hochtarif	
		0000	Wirkenergie Abgabe Niedertarif	(outgoing low tariff)
		0000	Wirkenergie Abgabe Hochtarif	(outgoing high tariff)
		0000*	Wirkenergie Bezug Niedertarif	(incoming low tariff)
12	0000 / .2 E.000	0000 ^{Mk} Wh*	Anzahl Impulse pro angezeigte Energie einheit. Nach Eingabe der Zahl 1 bis 5000 kann noch die Skalierung Grundeinheit (-), Kilo (k), Mega (M) und Giga (Mk) eingegeben werden	(energy rate)
		1 bis 5000 / Wh bis GWh		
13	5000 E.000	0000* 1 bis 60 Minuten	Zeitintervall in Minuten für die Berechnung der Intervall-Leistungen 0 = Intervall über Bus gesteuert	Bei externer Synchronisation ist der angezeigte Wert irrelevant.

Beispiele

Beispiel 1: Programmierung der Anschlussart
(3-Leiter ungleich belastet)

1. -Taste drücken > 2 s

0000
0000
E4PE
2. -Taste drücken (zeigt aktuelle Einstellung)

0000
E4PE
4000
3. -Taste drücken (programmierbare Größe blinkt)

0000
E4PE
4000
4. / -Taste drücken (gewünschten Parameter wählen)

0000
E4PE
3000

5. -Taste drücken (Programmierung übernehmen). Die Anzeige blinkt nun nicht mehr.





















0000
E4PE
3000
6. -Taste drücken > 2 s (Rückkehr in die Anzeigeebene)













Beispiel 2: Programmierung Spannungs-Wandlerverhältnis und Energieintervall

1. -Taste drücken > 2 s

0000
0000
E4PE
2. -Taste drücken (Menü Wandlerfaktoren)

0000
0000
0000

3.  -Taste drücken (aktuelle Einstellung Primärspannung)

4.  -Taste drücken (linke Ziffer blinkt)

5.  bzw.  -Taste drücken bis gewünschte Ziffer erscheint
6.  -Taste drücken (mittlere Ziffer blinkt)
7.  bzw.  -Taste drücken bis gewünschte Ziffer erscheint
8.  -Taste drücken (rechte Ziffer blinkt)
9.  bzw.  -Taste drücken bis gewünschte Ziffer erscheint
10.  -Taste drücken (Dezimalpunkt blinkt)
11.  bzw.  -Taste drücken bis Dezimalpunkt an gewünschter Stelle ist und die Kilo/Mega-Symbole stimmen
12.  -Taste drücken (Programmierung übernehmen). Die Anzeige blinkt nun nicht mehr
13.  -Taste drücken (aktuelle Einstellung Sekundärspannung)

14. Programmierung wie Primärspannung (Punkt 1 bis 12)
15.  -Taste drücken bis in der oberen Anzeige  erscheint

16.  -Taste 3x drücken

17.  -Taste drücken (aktuelle Einstellung in Minuten)

18.  -Taste drücken (linke Ziffer blinkt)

19.  bzw.  -Taste drücken bis gewünschte Ziffer erscheint
20.  -Taste drücken (rechte Ziffer blinkt)
21.  bzw.  -Taste drücken bis gewünschte Ziffer erscheint
22.  -Taste drücken (Programmierung übernehmen). Die Anzeige blinkt nun nicht mehr
23.  -Taste > 2 s drücken (Rückkehr in die Anzeigeebene)

Description brève

Les appareils A210/A220 sont des instruments pour montage encasturé du format 96 x 96 mm (A 210) ou 144 x 144 mm (A 220) et sert à l'analyse de réseaux de courant alternatif. Il capte les tensions, les courants, la fréquence et l'angle de phase de réseaux mono- et triphasés. Ainsi, il est possible de calculer les grandeurs suivantes: puissance active, réactive et apparente, énergies active et réactive, facteur de puissance et courant du neutre. En connexion avec des transformateurs d'intensité et de tension avec rapports programmables, l'appareil peut être utilisé dans des réseaux à moyenne et basse tension. L'appareil sert à l'affichage avec deux sorties S0 resp. détecteurs de valeur limite.

Caractéristiques techniques

(Pour plus de détails, voir notice A210/A220 Lf, download sous www.camillebauer.com)

Entrées de mesure

Fréquence nominale:	50, 60 Hz
Tension nominale d'entrée:	Phase-phase: 500 V Phase-neutre: 290 V
Courant nominal d'entrée:	5 A ou 1 A

Augmentation perm. admissible des grand. d'entrée

10 A à 346 V dans réseau monophasé
10 A à 600 V dans réseau de courant triphasé

Augmentation temp. admissible des grand. d'entrée

Grandeur d'entrée augmentée	Nombre d'augmentations de valeur	Durée des augmentations	Intervalle entre deux augmentations successives
577 V LN	10	1 s	10 s
100 A	10	1 s	100 s
100 A	5	3 s	5 min

Etendues de mesure

U, I, S:	≤ 120% de la valeur nominale
P, Q:	≤ ± 120% de la valeur nominale
F:	45 à 65 Hz
cosφ:	± 1

Sorties d'impulsions, sorties de valeur limite

Les deux sorties numériques travaillent suivant la fonction choisie soit sous forme d'impulsions pour l'énergie active resp. réactive, soit comme détecteur de valeur limite.

Les sorties sont passives et séparées de tous les autres circuits par des coupleurs optoélectroniques. Ils peuvent activer des compteurs tarifaires (S0-standard DIN 43 864) ou des relais 24 V.

U _{ext}	≤ 40 V CC (OFF: Courant de fuite ≤ 0,1 mA)
I _L	≤ 150 mA (ON: Tension des bornes ≤ 1,2 V)

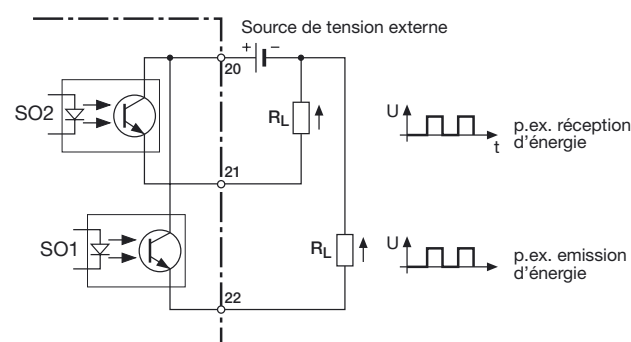

Sorties de valeurs limites

Les grandeurs de mesures peuvent librement être attribuées.

Sorties d'impulsions

Permettent de générer des impulsions de valeurs d'énergie active et réactive pour alimenter des compteurs électromécaniques ou électroniques.

Energie auxiliaire*

Bloc d'alimentation CC, CA 45 à 400 Hz
85 à 253 V CA/CC ou 20 à 70 V CA/CC
Consommation: < 3 VA (sans module d'extension)

* Pour une alimentation auxiliaire > 125 V CC, il faut équiper le circuit d'alimentation d'un fusible externe.

Conditions de référence selon CEI 688 resp. EN 60 688

Sinusoidal 50 - 60 Hz, 15 - 30°, groupe d'utilisation II

Précision (par rapport aux valeurs nominales)

Courant, tension	± 0,5%
Puissance	± 1,0%
Facteur de puissance	± 1,0%
Energie	± 1,0%
Fréquence	± 0,02 Hz (absolut)

Ambiance extérieure

Temp. de fonctionnement:	-10 à +55 °C
Température de stockage:	-25 à +70 °C
Humidité relative:	≤ 75%
Altitude:	2000 m max.

Utiliser seulement dans les intérieurs

Sécurité

Classe de protection:	II (entrées de tension avec impédances de protection)
Catégorie de mesure:	III
Degré d'encrassement:	2
Tension de référence:	300 V
Tensions d'essai:	Entre entrées courant, tension d'alimentation, sorties numérique, bornes du module embrochable: 3700 V / 50 Hz / 1 min. Aux entrées de tension: 4,25 kV 1,2/50 μs
Raccordement du module:	La barre des broches au dos de l'appareil et connectée à travers une impédance de protection aux entrées tension. Seulement des modules approuvés doivent être embrochés!
Protection:	Face avant IP 66, bornes IP 20

Conseils pour la maintenance

L'indicateur de puissances ne nécessite pas d'entretien.

Affichage

L'affichage est réalisé en partent de la droite à 3 chiffres, resp. 4 chiffres pour la fréquence à l'exception des valeurs d'énergie qui elles comportent 8 chiffres. L'affichage à 7 segments toute à gauche permet l'indiction de signes resp. d'abréviations.

Abréviations:

	Valeur maximale
	Valeur minimale
	Valeur moyenne
	Valeur moyenne maximum
	Valeur minimum pour facteur de puissance la valeurs la plus mauvaise des 3 P1, P2 et P3 est affichée
	Courant du neutre
	Inductive
	Capactive
	incoming, reçu
	outgoing, fourni
	Intervalle puissance active
	Intervalle puissance réactive
	Intervalle puissance apparente
	dernier intervalle; t-0
	avant-dernier intervalle; t-1, -2, -3, -4
	Overload, affichage de dépassement d'étendue
	Valeur du système
	Tensions entre phases

Compteur d'énergie

.H Valeur du système
.L Tensions entre phases

Intervalle 0 **Intervalle 1** **Intervalle 2** **Intervalle 3** **Intervalle 4**

Temps actuel t t-0 t-1 t-2 t-3 t-4

Suppression du point zéro

PF resp. $\cos\varphi$: Indication ---, si $S_x < 0,2\%$ S_{nenn}
 Courants: Indication 0, si $I_x < 0,1\%$ I_{nenn}

Mise en service

L'indicateur de puissances peut être mis en service par l'enclenchement de l'alimentation auxiliaire. Les affichages suivants se succèdent alors:

- Test des segments:** Tous les segments de l'affichage et toutes les DEL s'allument pour 2 s.
- Version du logiciel:** p. ex. A 210 1.04
- Les 3 tensions de phase lors de la première mise en service.

Coupage de l'énergie auxiliaire

En cas de coupure de l'énergie auxiliaire, toutes les valeurs programmées restent en mémoire. Après le réenclenchement de l'énergie auxiliaire, le dernier mode de fonctionnement est affiché.

Raccordements électriques

Les raccordements électriques pour SINEAX A 210 et A 220 sont identiques.

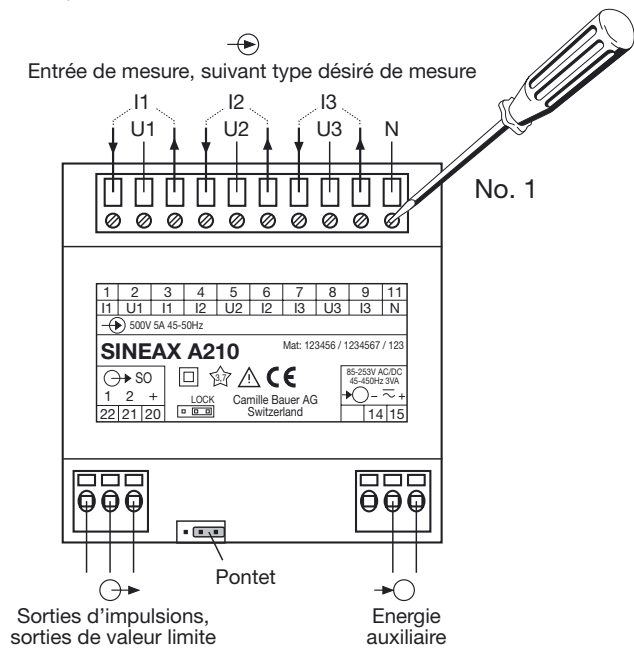

Possibilités de raccordement

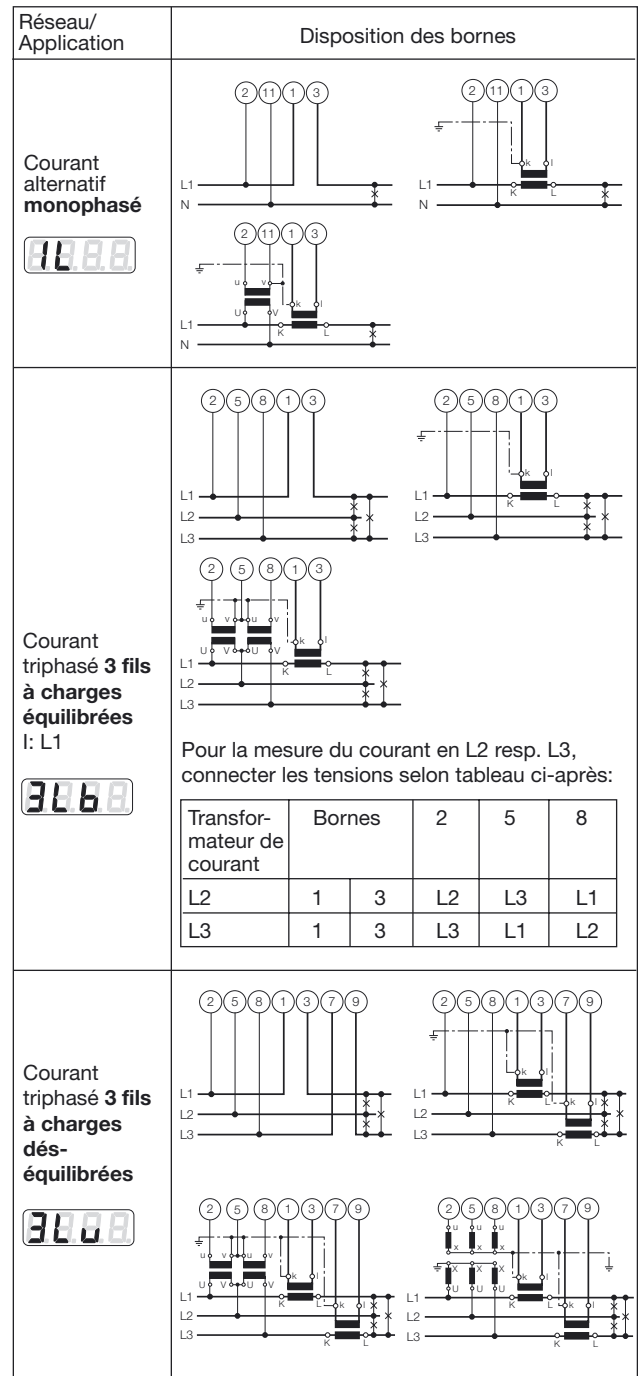

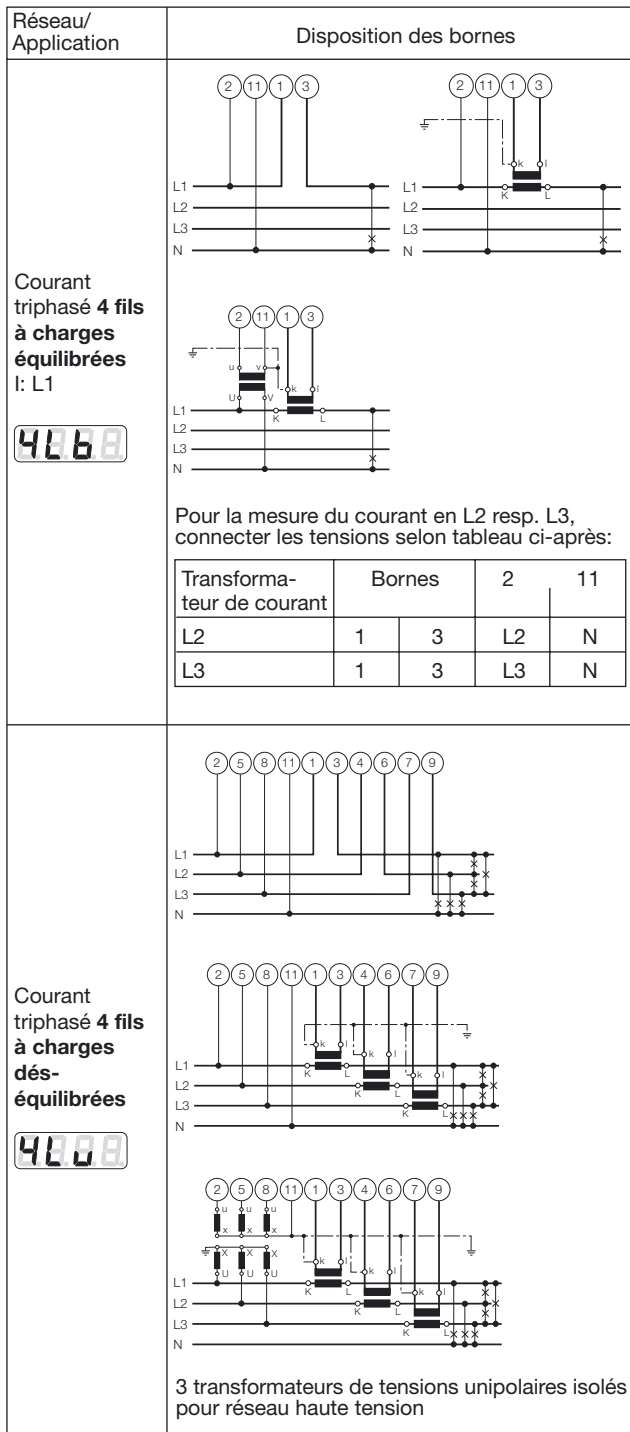

Affichage et utilisation

L'affichage et utilisation pour SINEAX A 210 et A 220 sont identiques.

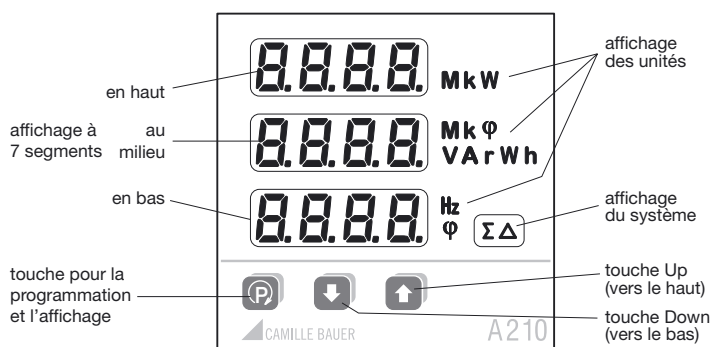

Facteur de puissance cosφ mode 4 quadrants

Données de mesure disponibles	Exemple Affichage en haut	Exemple Affichage au centre	Exemple Affichage en bas	Affichage unités	Affichage système
Tensions des phases U1, U2, U3	230	231	229	V	
Valeurs maximum U1 _{max.} , U2 _{max.} , U3 _{max.}	235	236	231	V	
Valeurs minimum U1 _{min.} , U2 _{min.} , U3 _{min.}	227	226	225	V	
Tensions entre phases U12, U23, U31	400	402	398	V	Δ
Valeurs maximum U12 _{max.} , U23 _{max.} , U31 _{max.}	405	406	403	V	Δ
Valeurs minimum U12 _{min.} , U23 _{min.} , U31 _{min.}	395	397	396	V	Δ
Courants des phases I1, I2, I3	2.35	2.37	2.34	A	
Valeurs maximum I1 _{max.} , I2 _{max.} , I3 _{max.}	2.39	2.40	2.38	A	
Valeur moyenne I1 _{avg.} , I2 _{avg.} , I3 _{avg.} (bimétallique -15 min.)	2.04	2.05	2.07	A	
Val. moyenne max. I1 _{avgmax.} , I2 _{avgmax.} , I3 _{avgmax.} (aiguille entraînée -15 min.)	2.07	2.05	2.04	A	
Courant du neutre IN	0.45	0.45		A	
Puissances active P1, P2, P3	56.1	56.2	56.5	kW	
Valeurs maximum P1 _{max.} , P2 _{max.} , P3 _{max.}	60.5	60.4	60.3	kW	
Puissance active, système P		125		kW	Σ
Valeur maximum P _{max.}		239		kW	Σ
Puissance réactive Q1, Q2, Q3	1.24	1.23	1.22	VAr	
Valeurs maximum Q1 _{max.} , Q2 _{max.} , Q3 _{max.}	1.51	1.52	1.54	VAr	
Puissance réactive système Q		1.54		VAr	Σ
Valeur maximum Q _{max.}		2.31		VAr	Σ
Puissances apparente S1, S2, S3	2.56	2.58	2.60	VA	
Valeurs maximum S1 _{max.} , S2 _{max.} , S3 _{max.}	3.43	3.44	3.67	VA	
Puissance apparente système S		5.33		VA	
Valeur maximum S _{max.}		6.23		VA	Σ
Facteur de puissance PF1, cosφ	0.87	0.87	0.87	φ	
Facteur de puissance PF2, cosφ	0.88	0.88	0.88	φ	
Facteur de puissance PF3, cosφ	0.89	0.89	0.89	φ	
Facteur de puissance système PF, cosφ		0.88		φ	Σ
Valeur min. facteur de puissance inductif	0.76	0.76	0.76	φ	Σ
Valeur min. facteur de puissance capacitif	0.84	0.84	0.84	φ	Σ
Fréquence, F			49.99	Hz	
Energie active reçu EP tarif normal	4589	2356	4589	kWh	Σ
Energie active reçu EP tarif réduit *)	1234	5678	1234	kWh	Σ
Energie active fourni EP tarif normal	4589	2356	4589	kWh	Σ
Energie active fourni EP tarif réduit *)	1234	5678	1234	kWh	Σ
Energie réactive inductive EQ tarif normal	9876	5432	9876	kVarh	Σ
Energie réactive inductive EQ tarif réduit *)	1234	9876	1234	kVarh	Σ
Energie réactive capacitive EQ tarif normal	9876	5432	9876	kVarh	Σ
Energie réact. capacitive EQ tarif réduit *)	1234	9876	1234	kVarh	Σ
5 intervalle puiss. active Pint0, Pint1, ...	234	234	234	kW	Σ
5 intervalle puiss. réactive Qint0, Qint1, ...	123	123	123	VAr	Σ
5 intervalle puissance apparente Sint0, Sint1, ...	10.1	10.1	10.1	VA	Σ

*) Changement de tarif seulement avec un entrée digital (option module d'extension)

Calcul des grandeurs mesurées: Le calcul des grandeurs mesurées se fait en accord avec DIN 40 110, à l'exception de la puissance réactive. Le SINEAX A 210/A 220 calcule celle-ci en tenant compte du signe.

Des convertisseurs de mesure resp. des indicateurs peuvent donc éventuellement afficher des valeurs différentes pour la puissance réactive. La raison à ceci est à chercher dans les différentes méthodes de calcul.

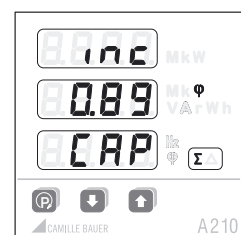

Système

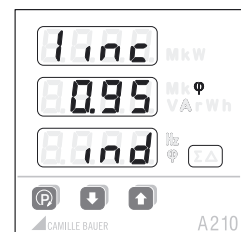

Phase 1

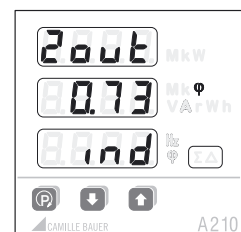

Phase 2

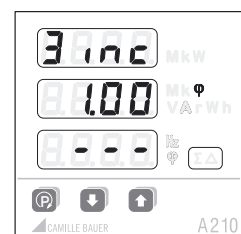

Phase 3

Niveaux d'affichage

En dedans d'un niveau (1, 2, 3, ...), vous pouvez commuter les 3 affichages au mode suivant (a, b, c, ...) en appuyant sur la touche . Au bout du mode, l'affichage recommence automatiquement au mode a.

En appuyant brièvement sur l'une des touches ou , vous pouvez passer au niveau suivant.

4 fils à charges déséquilibrées

		a	b	c	d	e	f
 	1	U1 U2 U3	U1 _{max.} U2 _{max.} U3 _{max.}	U1 _{min.} U2 _{min.} U3 _{min.}	U12 U23 U31	U12 _{max.} U23 _{max.} U31 _{max.}	U12 _{min.} U23 _{min.} U31 _{min.}
	2	I1 I2 I3	I1 _{max.} I2 _{max.} I3 _{max.}	I1 _{avg.} I2 _{avg.} I3 _{avg.}	I1 _{avgmax.} I2 _{avgmax.} I3 _{avgmax.}	IN	IN _{max.}
	3	P1 P2 P3	P1 _{max.} P2 _{max.} P3 _{max.}	P	P _{max.}		
	4	Q1 Q2 Q3	Q1 _{max.} Q2 _{max.} Q3 _{max.}	Q	Q _{max.}		
	5	S1 S2 S3	S1 _{max.} S2 _{max.} S3 _{max.}	S	S _{max.}		
	6	PF1	PF2	PF3	PF	PF _{minind}	PF _{mincap}
	7	F					
	8	EP inc HT ¹	EP inc LT ²	EP out HT ¹	EP out LT ²		
	9	EQ ind HT ¹	EQ ind LT ²	EQ cap HT ¹	EQ cap LT ²		
	10	P Q PF	P S F				
	11	Pint0	Pint1	Pint2	Pint3	Pint4	
	12	Qint0	Qint1	Qint2	Qint3	Qint4	
	13	Sint0	Sint1	Sint2	Sint3	Sint4	

3 fils à charges déséquilibrées

		a	b	c	d	e
 	1	U12 U23 U31	U12 _{max.} U23 _{max.} U31 _{max.}	U12 _{min.} U23 _{min.} U31 _{min.}		
	2	I1 I2 I3	I1 _{max.} I2 _{max.} I3 _{max.}	I1 _{avg.} I2 _{avg.} I3 _{avg.}	I1 _{avgmax.} I2 _{avgmax.} I3 _{avgmax.}	
	3	P	P _{max.}			
	4	Q	Q _{max.}			
	5	S	S _{max.}			
	6	PF	PF _{minind}	PF _{mincap}		
	7	F				
	8	EP inc HT ¹	EP inc LT ²	EP out HT ¹	EP out LT ²	
	9	EQ ind HT ¹	EQ ind LT ²	EQ cap HT ¹	EQ cap LT ²	
	10	P Q PF	P S F			
	11	Pint0	Pint1	Pint2	Pint3	Pint4
	12	Qint0	Qint1	Qint2	Qint3	Qint4
	13	Sint0	Sint1	Sint2	Sint3	Sint4

Monophasé, 3 fils à charges équilibrées, 4 fils à charges équilibrées

		a	b	c	d	e
 	1	U	U _{max.}	U _{min.}		
	2	I	I _{max.}	I _{avg.}	I _{avgmax.}	
	3	P	P _{max.}			
	4	Q	Q _{max.}			
	5	S	S _{max.}			
	6	PF	PF _{minind}	PF _{mincap}		
	7	F				
	8	EP inc HT ¹	EP inc NT ²	EP out HT ¹	EP out NT ²	
	9	EQ ind HT ¹	EQ ind NT ²	EQ cap HT ¹	EQ cap NT ²	
	10	P Q PF	P S F			
	11	Pint0	Pint1	Pint2	Pint3	Pint4
	12	Qint0	Qint1	Qint2	Qint3	Qint4
	13	Sint0	Sint1	Sint2	Sint3	Sint4

Utilisation

Luminosité

13 gradins: appuyer longuement sur les touches (plus foncé) ou (plus clair).

Effacer / Clear

En appuyant simultanément sur les touches les valeurs min. et max. resp. les valeurs d'énergie sont effacées.

Blocage

La remise à zéro des compteurs d'énergie peut être bloquée en plaçant le pontet respectif à l'arrière de l'appareil en position LOCK.

¹ HT = Tarif normal

² LT = Tarif réduit

Programmation

Tous les paramètres peuvent à chaque instant être affichés. Pour des modifications, il faut toutefois retirer le pontet placé au dos de l'appareil (position pas sur LOCK).



Le tableau suivant indique tous les paramètres avec la gamme des étendues resp. les sélections possibles. Les numéros en noir renvoient au point respectif des diagrammes de la page 30.

En appuyant longuement sur la touche  on passe de l'affichage au niveau Menu.

Le point désiré du menu s'atteint en appuyant brièvement la touche .

Par la touche  on arrive au niveau paramètres qui permet l'affichage des paramètres désirés.

En appuyant brièvement la touche , l'élément désiré commence à clignoter.

La valeur qui clignote peut être modifiée par les touches  / .

En appuyant longuement la touche  il est possible de sortir des niveaux Menu et Paramètres.

Les valeurs programmées restent mémorisées en cas de manque de tension d'alimentation.

Informations importantes:

Le genre de raccordement et les rapports des transformateurs de mesure doivent toujours être introduites en premier, étant donnée que les affichages des valeurs mesurées, des valeurs limites etc., en dépendent.

La programmation peut également être modifiée par le module d'extension (en option).

Blocage de la programmation

Pontet dans la position LOCK.

La programmation de toutes les valeurs est bloquée.



































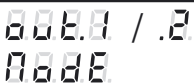











LOCK











Réglage en usine

Luminosité:	(valeur moyenne)
Valeur limite/S01:	Off
Valeur limite/S02:	Off
Rapport des transformateurs de mesure:	1 : 1
Pontet:	pas dans la position LOCK
Possibilités de raccordement:	4 fils déséquilibrées
Intervalle synchrone:	15 min.

Aperçu des paramètres







No.	Affichage en haut Affichage au centre	Affichage en bas (Sélection, * = Default)	Signification	Information
1	 		Possibilités de raccordement	
		 *	4 fils à charges déséquilibrées	(4 lines unbalanced)
			3 fils à charges déséquilibrées	(3 lines unbalanced)
			4 fils à charges équilibrées	(4 lines balanced)
			3 fils à charges équilibrées	(3 lines balanced)
		Monophasé	(1 line)	
2	 		Nature de charge pour récupération d'énergie: Mathématique	Affichage 4 quadrants Ind-Cap-Ind-Cap
			Nature de charge pour récupération d'énergie: Electrique	Affichage 4 quadrants Ind-Ind-Cap-Cap
3	 	 kV 100 V à 999 kV	Tension primaire du transformateur de mesure sur l'entrée tension (tension entre phases)	D'abord introduire un chiffre quelconque à 3 chiffres et l'unité et ensuite par pas avec le facteur 10
4	 	 V 100 V à 999 V	Tension secondaire du transformateur de mesure sur l'entrée tension (tension entre phases)	
5	 	 A 1,00 A à 999 kA	Courant primaire du transformateur de mesure sur l'entrée courant	
6	 	 A 0,1 A à 9,99 A	Courant secondaire du transformateur de mesure sur l'entrée courant	



No.	Affichage en haut Affichage au centre	Affichage en bas (Sélection, * = défaut)	Signification	Information		
7			Mode de fonctionnement des deux sorties numériques «out.1» et «out.2»	(mode)		
			Sortie déclenchée	La sélection de l'interface bus est toutefois possible		
			Sortie d'impulsions énergie	La sortie produit des impulsions d'énergie à la cadence ajustée sous 12. La valeur du chiffre de sortie est sélectionnée sous 11.		
			Sortie alarme	Lors du dépassement de la valeur limite 9, la sortie est activée (le courant passe) resp. passive pour la sortie au dessous de la valeur 10. Le choix de la grandeur à surveiller se réalise par 8.		
8			Grandeur avec alarme	Ce choix est proposé si le mode de fonctionnement 7 a préalablement été mis sur ALM		
				Line Type		
				'1L', '3Lb', '4Lb'	'3Lu'	'4Lu'
			Fréquence	●	●	●
			Courant du neutre			●
			Intervalle puissance apparente	●	●	●
			Intervalle puissance réactive	●	●	●
			Intervalle puissance active	●	●	●
			Facteur de puissance (cos φ)	●	●	○
			Puissance apparente	●	●	○
			Puissance réactive	●	●	○
			Puissance active	●	●	○
			Tension	●		
			Tension de phase			○
			Tension entre phases		○	○
	Courant de phase moyen (bimétal)	●	○	○		
	Courant de phase	●	○	○		
			○: 'A.on'= Condition OR des grand. de phase 'A.off'= Condition AND des grand. de phase			
9			Limite d'enclenchement de l'alarme	La valeur maximum dépend de l'étendue de mesure possible, des rapports des transformateurs de mesure et du genre de raccordement.		
10			Limite de déclenchement de l'alarme			

No.	Affichage en haut Affichage au centre	Affichage en bas (Sélection, * = défaut)	Signification	Information
11			Source du compteur d'énergie à impulsions	
			Energie réactive capacitive tarif réduit	
			Energie réactive capacitive tarif normal	
			Energie réactive inductive tarif réduit	
			Energie réactive inductive tarif normal	
			Energie active fournie tarif réduit	(outgoing low tariff)
			Energie active fournie tarif normal	(outgoing high tariff)
12		 1 à 5000 / Wh à GWh	Nombre d'impulsions par unité d'énergie. Après sélection d'un chiffre entre 1 à 5000, il est possible d'introduire la valeur de base (-), Kilo (k), Mega (M) et Giga (Mk)	(energy rate)
13		 1 à 60 min.	Intervalle en minutes pour le calcul de la puissance à intervalles 0 = Intervalle piloté par bus	En cas de synchronisation externe, la valeur affichée est insignifiante.

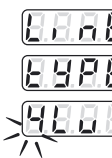

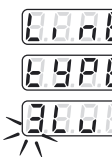

Exemples

Exemple 1: Programmation de la possibilité de raccordement (3 fils à charges déséquilibrées)

- Appuyer la touche  > 2 s

- Appuyer la touche  (indique l'ajustage actuel)

- Appuyer la touche  (la grandeur qui peut être programmée clignote)

- Appuyer la touche  /  (sélectionner le paramètre désiré)

- Appuyer la touche  (introduire la programmation). L'affichage ne clignote plus.

- Appuyer la touche  > 2 s (retour au niveau d'affichage)

Exemple 2: Programmation du rapport des transformateurs de mesure de tension et de l'intervalle de la mesure d'énergie









- Appuyer la touche  > 2 s

- Appuyer la touche  (menu rapports des transformateurs)

3. Appuyer la touche  (ajustage actuel de la tension primaire)





4. Appuyer la touche  (le chiffre à gauche clignote)



5. Appuyer les touches  ou  jusqu'à apparition du chiffre désiré
6. Appuyer la touche  (le chiffre du milieu clignote)
7. Appuyer les touches  ou  jusqu'à apparition du chiffre désiré
8. Appuyer la touche  (le chiffre à droite clignote)
9. Appuyer les touches  ou  jusqu'à apparition du chiffre désiré
10. Appuyer la touche  (le point décimal clignote)
11. Appuyer les touches  ou  jusqu'à ce que le point décimal soit au bon endroit et que les symboles Kilo/Mega désirés soient placés
12. Appuyer la touche  (introduire la programmation). L'affichage ne clignote plus.
13. Appuyer la touche  (ajustage actuel de la tension secondaire)



14. Programmation comme pour la tension primaire (point 1 à 12)
15. Appuyer la touche  jusqu'à apparition de l'affichage 

16. Appuyer 3 fois la touche 









17. Appuyer la touche  (affichage actuel en minutes)



18. Appuyer la touche  (le chiffre à gauche clignote)



19. Appuyer les touches  ou  jusqu'à apparition du chiffre désiré
20. Appuyer la touche  (le chiffres à droite clignote)
21. Appuyer les touches  ou  jusqu'à apparition du chiffre désiré
22. Appuyer la touche  (introduire la programmation). L'affichage ne clignote plus.
23. Appuyer la touche  > 2 s (retour au niveau d'affichage)

Brief description

The A 210/A 220 are panel mounting instruments for monitoring AC systems with dimensions 96 x 96 mm (A 210) and 144 x 144 mm (A 220). The following measurements are acquired: voltages, currents, frequency, and phase angles in single phase or 3 phase systems. From these, the active power, reactive power, apparent power, active energy, reactive energy, and the power factor and the neutral current can be calculated. With the use of voltage and current transformers, the instrument can be used for measurements in medium and high voltage systems. The transformation ratios are configurable for the direct display of all measurements. The A 210/A 220 instrument is used as a display with two S0 pulse or limit value outputs.

Technical data

(for more detailed information please see data sheet, download under www.camillebauer.com)

Measuring inputs

Nominal frequency:	50, 60 Hz
Nominal input voltage:	Phase-phase: 500 V Phase - N: 290 V
Nominal input current:	5 A or 1 A

Continuous thermal ratings of inputs

10 A at 346 V single phase AC system
10 A at 600 V three phase system

Short-time thermal rating of inputs

Input variable	Number of inputs	Duration of overload	Interval between two overloads
577 V LN	10	1 s	10 s
100 A	10	1 s	100 s
100 A	5	3 s	5 min

Measuring ranges

U, I, S:	≤ 120% of nominal value
P, Q:	≤ ± 120% of nominal value
F:	45 to 65 Hz
cosφ:	± 1

Pulse/Limit value outputs

Depending on the function selected, the two digital outputs can be used either as pulse outputs for active and reactive energy or as limit signals.

The outputs are passive, and are galvanically isolated from all the other circuits by opto-couplers. They are suitable to drive tariff devices (S0-standard DIN 43 864) or 24 V-relays.

U_{ext}	≤ 40 V DC (OFF: leakage current ≤ 0.1 mA)
I_L	≤ 150 mA (ON: terminal voltage ≤ 1.2 V)

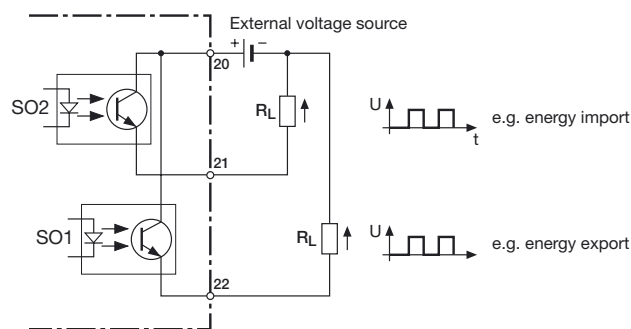

Limit value outputs

Any measured value can be allocated to the limit values.

Impulse outputs

Active and reactive energy impulses can be generated for driving electronic and electromechanical energy meters.

Power supply*

DC, AC power pack 45 to 400 W
85 to 253 V AC/DC or 20 to 70 V AC/DC
Power input: < 3 VA (without extension module)

* For power supplies > 125 V the auxiliary circuit should include an external fuse.

Reference conditions acc. to IEC 688 resp. EN 60 688

Sine 50 - 60 Hz, 15 - 30°, application group II

Measurement accuracy (related to nominal value)

Current, voltage	± 0.5%
Power	± 1.0%
Power factor	± 1.0%
Energy	± 1.0%
Frequency	± 0.02 Hz (abs.)

Environmental conditions

Operating temperature:	-10 to +55 °C
Storage temperature:	-25 to +70 °C
Relative humidity:	≤ 75%
Altitude:	2000 m max.
Indoor use statement	

Safety

Protection class:	II (voltage inputs with protection impedances)
Measuring category:	III
Pollution degree:	2
Measurement voltage:	300 V
Test voltage:	Between current inputs, power supply, digital outputs, terminals of the plugged-in module: 3700 V / 50 Hz / 1 min. At voltage inputs: 4.25 kV 1.2/50 μs
Module connections:	The pin rail at the back is connected to the voltage inputs via a protection impedance. Only the permitted modules can be plugged-in!
Enclosure protection:	Front IP 66, terminals IP 20

Note of maintenance

No maintenance is required.

Display

The measurement display is 3 digit resp. 4 digit (frequency) and right justified, with the exception of the energy values which are 8 digits. The left-hand 7-segment display is for the sign or an abbreviation.

Abbreviations:

	Maximal value
	Minimal value
	Average value
	Max. average value
	Minimal value for power factor; the worst out of the 3 values of P1, P2, or P3 is displayed
	Neutral current
	Inductive
	Capacitive
	Incoming
	Outgoing
	Interval active power
	Interval reactive power
	Interval apparent power
	Last interval; t-0
	Previous interval; t-1, -2, -3, -4
	Overload, out of range indicator
Σ	System value
Δ	Delta voltage

Energy meter

- .H High tariff
- .L Low tariff

	Interval 0	Interval 1	Interval 2	Interval 3	Interval 4
Current time t	t-0	t-1	t-2	t-3	t-4

Zero value suppression

PF resp. $\cos\phi$: Display ---, if $S_x < 0.2\% S_{nenn}$
 Currents: Display 0, if $I_x < 0.1\% I_{nenn}$

Commissioning

The multi-functional power monitor is made operational by switching on the power supply. The following appears sequentially on the display:

- Segment tests:** all the segments of the displays and all the LEDs are lit for 2 s.
- Version of the software:** e.g. A 210 1.04
- The 3 line voltages at switching on.

Loss of the power supply

All the values configured remain during a loss of the power supply. On reconnecting the power supply, the last mode selected is displayed.

Electrical connections

The electrical connections are identical for the SINEAX A 210 and A 220).

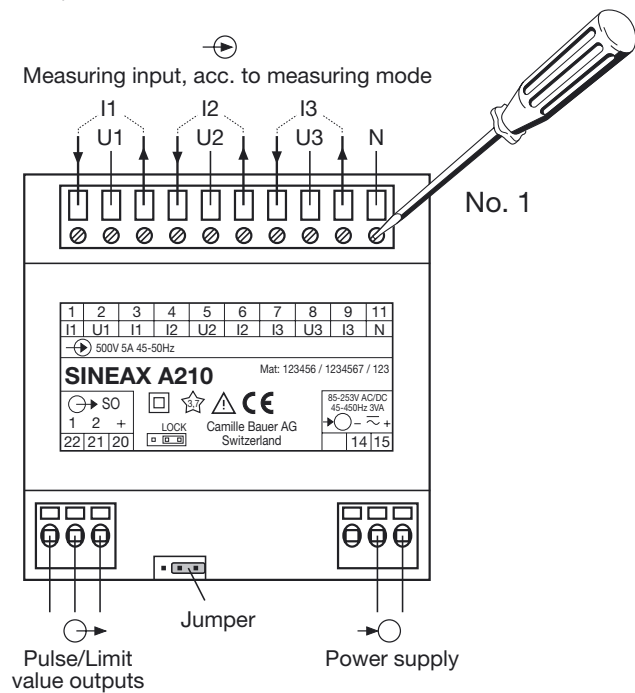

Connecting modes

System/application	Terminals																	
Single phase AC system 																		
3wire 3 phase symmetric load I: L1 	Connect the voltage according to the following table for current measurement in L2 or L3: <table border="1"> <thead> <tr> <th>Current transf.</th> <th>Terminals</th> <th>2</th> <th>5</th> <th>8</th> </tr> </thead> <tbody> <tr> <td>L2</td> <td>1</td> <td>3</td> <td>L2</td> <td>L3</td> <td>L1</td> </tr> <tr> <td>L3</td> <td>1</td> <td>3</td> <td>L3</td> <td>L1</td> <td>L2</td> </tr> </tbody> </table>	Current transf.	Terminals	2	5	8	L2	1	3	L2	L3	L1	L3	1	3	L3	L1	L2
Current transf.	Terminals	2	5	8														
L2	1	3	L2	L3	L1													
L3	1	3	L3	L1	L2													
3 wire 3 phase asymmetric load 																		

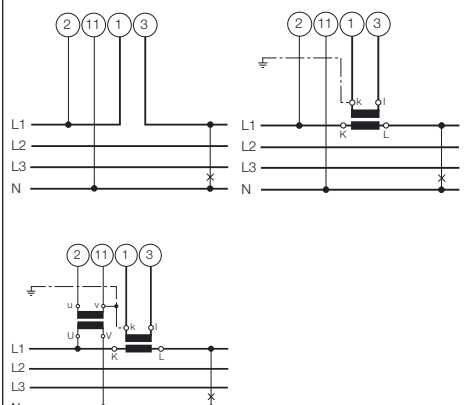
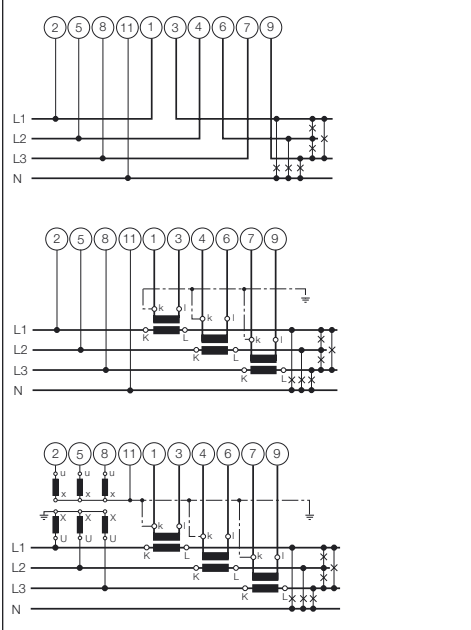
System/ application	Terminals															
<p>4 wire 3 phase symmetric load I: L1</p> <p>4L68</p>	 <p>Connect the voltage according to the following table for current measurement in L2 or L3:</p> <table border="1" data-bbox="255 739 710 851"> <thead> <tr> <th>Current trans.</th> <th colspan="2">Terminals</th> <th>2</th> <th>11</th> </tr> </thead> <tbody> <tr> <td>L2</td> <td>1</td> <td>3</td> <td>L2</td> <td>N</td> </tr> <tr> <td>L3</td> <td>1</td> <td>3</td> <td>L3</td> <td>N</td> </tr> </tbody> </table>	Current trans.	Terminals		2	11	L2	1	3	L2	N	L3	1	3	L3	N
Current trans.	Terminals		2	11												
L2	1	3	L2	N												
L3	1	3	L3	N												
<p>4 wire 3 phase asymmetric load</p> <p>4L88</p>	 <p>3 single-pole insulated voltage transformers in high-voltage system</p>															

Display and operating

Display and operating are identical for the SINEAX A 210 and A 220

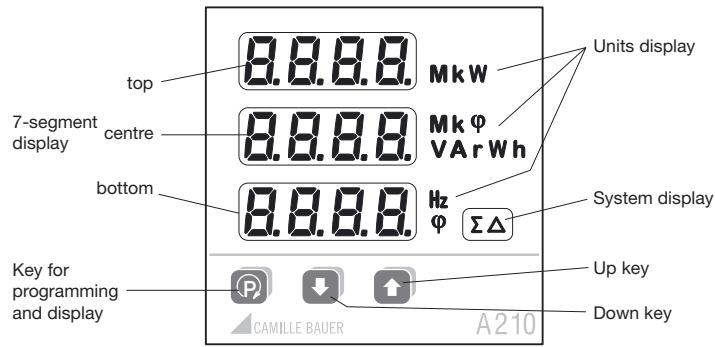

Available measurement data	Example display top	Example display centre	Example display bottom	Units display	System display
Phase voltages U1, U2, U3	230	231	229	V	
Maximum value U1 _{max.} , U2 _{max.} , U3 _{max.}	235	236	231	V	
Minimum value U1 _{min.} , U2 _{min.} , U3 _{min.}	227	226	225	V	
Delta voltages U12, U23, U31	400	402	398	V	Δ
Maximum values U12 _{max.} , U23 _{max.} , U31 _{max.}	405	406	403	V	Δ
Minimum values U12 _{min.} , U23 _{min.} , U31 _{min.}	395	397	396	V	Δ
Phase current I1, I2, I3	2.35	2.37	2.34	A	
Maximum values I1 _{max.} , I2 _{max.} , I3 _{max.}	2.39	2.40	2.38	A	
Average values I1 _{avg.} , I2 _{avg.} , I3 _{avg.} (bimetal -15 min.)	2.04	2.05	2.07	A	
Max. average values I1 _{avgmax.} , I2 _{avgmax.} , I3 _{avgmax.} (slave pointer-15 min.)	2.07	2.05	2.04	A	
Neutral current IN	0.00	0.45		A	
Active powers P1, P2, P3	56.1	56.2	56.5	kW	
Maximum values P1 _{max.} , P2 _{max.} , P3 _{max.}	60.5	60.4	60.3	kW	
Active power system P		125		kW	Σ
Maximum value P _{max.}		239		kW	Σ
Reactive power Q1, Q2, Q3	1.24	1.23	1.22	VAR	
Maximum values Q1 _{max.} , Q2 _{max.} , Q3 _{max.}	1.51	1.52	1.54	VAR	
Reactive power system Q		1.54		VAR	Σ
Maximum value Q _{max.}		2.31		VAR	Σ
Apparent power S1, S2, S3	2.56	2.58	2.60	VA	
Maximum values S1 _{max.} , S2 _{max.} , S3 _{max.}	3.43	3.44	3.67	VA	
Apparent power system S		5.33		VA	
Maximum value S _{max.}		6.23		VA	Σ
Power factor PF1, cosφ	0.87	0.87	0.87	φ	
Power factor PF2, cosφ	0.88	0.88	0.88	φ	
Power factor PF3, cosφ	0.89	0.89	0.89	φ	
Power factor system PF, cosφ	0.88	0.88	0.88	φ	Σ
Minimum value power factor inductive	0.76	0.76	0.76	φ	Σ
Minimum value power factor capacitive	0.84	0.84	0.84	φ	Σ
Frequency, F			49.99	Hz	
Active energy incoming EP high tariff	4589	2356	4589	kWh	Σ
Active energy incoming EP low tariff *)	1234	5678	1234	kWh	Σ
Active energy outgoing EP high tariff	4589	2356	4589	kWh	Σ
Active energy outgoing EP low tariff *)	1234	5678	1234	kWh	Σ
Reactive energy inductive EQ high tariff	9876	5432	9876	kVarh	Σ
Reactive energy inductive EQ low tariff *)	1234	9876	1234	kVarh	Σ
Reactive energy capacitive EQ high tariff	9876	5432	9876	kVarh	Σ
Reactive energy capacitive EQ low tariff *)	1234	9876	1234	kVarh	Σ
5 active power intervals Pint0, Pint1, ...	234	234	234	kW	Σ
5 reactive power intervals Qint0, Qint1, ...	123	123	123	VAR	Σ
5 apparent power intervals Sint0, Sint1, ...	10.1	10.1	10.1	VA	Σ

*) Tariff switching via digital input only (optional extension module required)

Determination of measured quantities: The calculation of the measurements is made in accordance with DIN 40 110, with the exception of the reactive power. This is calculated by the SINEAX A 210/A 220 as a signed value.

Transducers and displays can possibly display different values for the reactive power in the same power system. The reason is the different calculation methods.

Power factor cosφ 4 quadrant operation

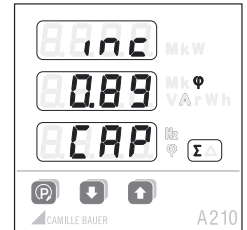

System

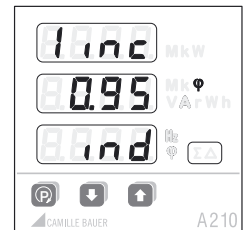

Phase 1

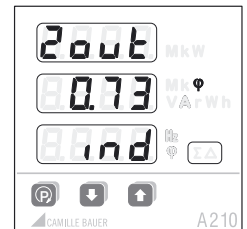

Phase 2

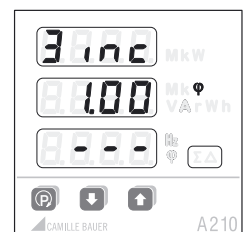

Phase 3

Display levels

Within a level (1, 2, 3 ...) you can change the 3 displays to the next mode (a, b, c, ...) with the **(P)** key. From the last mode, the display changes to mode a again.

Change to the next level with the **(↑)** and **(↓)** keys.

4 wire asymmetric load

		a	b	c	d	e	f	
 	1	U1 U2 U3	U1 _{max.} U2 _{max.} U3 _{max.}	U1 _{min.} U2 _{min.} U3 _{min.}	U12 U23 U31	U12 _{max.} U23 _{max.} U31 _{max.}	U12 _{min.} U23 _{min.} U31 _{min.}	
	2	I1 I2 I3	I1 _{max.} I2 _{max.} I3 _{max.}	I1 _{avg.} I2 _{avg.} I3 _{avg.}	I1 _{avgmax.} I2 _{avgmax.} I3 _{avgmax.}	IN	IN _{max.}	
	3	P1 P2 P3	P1 _{max.} P2 _{max.} P3 _{max.}	P	P _{max.}			
	4	Q1 Q2 Q3	Q1 _{max.} Q2 _{max.} Q3 _{max.}	Q	Q _{max.}			
	5	S1 S2 S3	S1 _{max.} S2 _{max.} S3 _{max.}	S	S _{max.}			
	6	PF1	PF2	PF3	PF	PF _{minind}	PF _{mincap}	
	7	F						
	8	EP inc HT ¹	EP inc LT ²	EP out HT ¹	EP out LT ²			
	9	EQ ind HT ¹	EQ ind LT ²	EQ cap HT ¹	EQ cap LT ²			
	10	P Q PF	P S F					
	11	Pint0	Pint1	Pint2	Pint3	Pint4		
	12	Qint0	Qint1	Qint2	Qint3	Qint4		
	13	Sint0	Sint1	Sint2	Sint3	Sint4		

Single-phase, 3 wire symmetric load, 4 wire symmetric load

		a	b	c	d	e
 	1	U	U _{max.}	U _{min.}		
	2	I	I _{max.}	I _{avg.}	I _{avgmax.}	
	3	P	P _{max.}			
	4	Q	Q _{max.}			
	5	S	S _{max.}			
	6	PF	PF _{minind}	PF _{mincap}		
	7	F				
	8	EP inc HT ¹	EP inc NT ²	EP out HT ¹	EP out NT ²	
	9	EQ ind HT ¹	EQ ind NT ²	EQ cap HT ¹	EQ cap NT ²	
	10	P Q PF	P S F			
	11	Pint0	Pint1	Pint2	Pint3	Pint4
	12	Qint0	Qint1	Qint2	Qint3	Qint4
	13	Sint0	Sint1	Sint2	Sint3	Sint4

Operating

Brightness

13 levels: continuous pressing of the **(↓)** key (darker), or the **(↑)** key (brighter).

Delete / Clear

To delete the min. or max. values, or the energy values of the displayed measurements, press the **(↓)** **(↑)** keys at the same time.

Locking

The reset function for the energy meters can be locked by setting the jumper at the rear of the instrument to the position LOCK.

3 wire asymmetric load

		a	b	c	d	e
 	1	U12 U23 U31	U12 _{max.} U23 _{max.} U31 _{max.}	U12 _{min.} U23 _{min.} U31 _{min.}		
	2	I1 I2 I3	I1 _{max.} I2 _{max.} I3 _{max.}	I1 _{avg.} I2 _{avg.} I3 _{avg.}	I1 _{avgmax.} I2 _{avgmax.} I3 _{avgmax.}	
	3	P	P _{max.}			
	4	Q	Q _{max.}			
	5	S	S _{max.}			
	6	PF	PF _{minind}	PF _{mincap}		
	7	F				
	8	EP inc HT ¹	EP inc LT ²	EP out HT ¹	EP out LT ²	
	9	EQ ind HT ¹	EQ ind LT ²	EQ cap HT ¹	EQ cap LT ²	
	10	P Q PF	P S F			
	11	Pint0	Pint1	Pint2	Pint3	Pint4
	12	Qint0	Qint1	Qint2	Qint3	Qint4
	13	Sint0	Sint1	Sint2	Sint3	Sint4

¹ HT = high tariff

² LT = low tariff

Programming

All parameters may be displayed at any time. For modifications the jumper on the backside of the device must be removed (not on position LOCK).

The following table shows all parameters with their adjustable ranges or possible selections respectively. The black numbers give a cross-reference to the appropriate diagram position on page 30.

Starting at the measurands display by pressing the key  you may change to the menu level.

Afterwards you can select the desired menu item by pressing the key  shortly.

Use  to enter the level where the desired parameter is displayed.

Pressing  shortly will force the selectable element to flash.

The flashing content may be modified using the keys  or .

Press  for a longer time to leave the parameter or menu level.

All settings will remain non-volatile stored even in case of power-fail.

Hints:

First you have to set the system configuration and the transformer ratios because further measurand selections, alarm limit settings etc. will depend on them.

The programming may be modified via an optional extension module as well.

Locking the configuration

Place the jumper in the LOCK position.











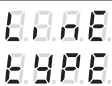





The configuration of all parameters is disabled.

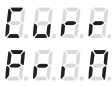

Factory Default

Brightness:	(mid setting)
Limit value / S01:	Off
Limit value / S02:	Off
Transformer ratio:	1 : 1
Jumper:	Not in the LOCK position
Connecting mode:	4 wire asymmetric load
Synchronizing interval:	15 min.

Parameters overview

No.	Topmost display Middle display	Undermost display (Selection, * = Default)	Meaning	Hints
1			System configuration	
			4-line system, unbalanced load	(4 lines unbalanced)
			3-line system, unbalanced load	(3 lines unbalanced)
			4-line system, balanced load	(4 lines balanced)
			3-line system, balanced load	(3 lines balanced)
2			Load type for energy recovery: Mathematical	4 quadrant display, ind-cap-ind-cap
			Load type for energy recovery: Electrical	4 quadrant display, ind-ind-cap-cap
3		 kV* 100 V to 999 kV	Primary voltage of an external transformer on the voltage (line-to-line voltage)	First you enter any 3-digit number followed by the appropriate power unit selection in steps of factor 10
4		 V* 100 V to 999 V	Secondary voltage of an external transformer on the voltage input (line-to-line voltage)	
5		 A* 1.00 A to 999 kA	Primary current of an external transformer on the current input	
6		 A* 0.1 A to 9,99 A	Secondary current of an external transformer on the current input	

No.	Topmost display Middle display	Undermost display (Selection, * = default)	Meaning	Hints		
7	888.8 / .2 8888		Operating mode of both digital outputs “out.1” and “out.2”	(mode)		
		8888 *	Output switched-off	Simulation via interface module is still possible		
		8888	Energy pulse output	The output generates energy pulses depending on the rate set under 12 . The meter measurands to output may be selected under 11 .		
		8888	Alarm output	If the alarm limit 9 is exceeded the output will be active (current flows). If the measurand is below limit 10 the output will be passive. The source of the monitored is selected under 8 .		
8	888.8 / .2 8888		Alarm supervision source	This selection is presented only if operating mode 7 is set to ALM previously		
				Line Type		
				'1L', '3Lb', '4Lb'	'3Lu'	'4Lu'
		8888	Frequency	●	●	●
		8888	Neutral current			●
		8888	Apparent power interval	●	●	●
		8888	Reactive power interval	●	●	●
		8888	Active power interval	●	●	●
		8888	Power factor (cos φ)	●	●	○
		8888	Apparent power	●	●	○
		8888	Reactive power	●	●	○
		8888	Active power	●	●	○
		8888	Voltage	●		
		8888 *	Line-neutral voltage			○
		8888	Line-to-line voltage		○	○
8888	Average current (bimetal)	●	○	○		
8888	Phase current	●	○	○		
				○: 'A.on'= OR-operation of line-measurands 'A.off'= AND-operation of line-measurands		
9	888.8 / .2 8888	8888 v *	Alarm limit for ON-state	The maximum values of the alarm limits depend on the possible measuring range (fixed by hardware), converted into possible primary values given by the selected system configuration and transformation ratios.		
10	888.8 / .2 8888	8888 v *	Alarm limit for OFF-state			

No.	Topmost display Middle display	Undermost display (Selection, * = default)	Meaning	Hints
11			Source of energy meters for pulse output	
			Reactive energy capacitive, low tariff	
			Reactive energy capacitive, high tariff	
			Reactive energy inductive, low tariff	
			Reactive energy inductive, high tariff	
			Active energy outgoing, low tariff	(outgoing low tariff)
			Active energy outgoing, high tariff	(outgoing high tariff)
12		Mk * Wh	Number of pulses per displayed energy unit. After entering a number from 1 to 5000 you may input the scaling: Basic unit (-), kilo (k), Mega (M) or Giga (Mk)	(energy rate)
		1 to 5000 / Wh to GWh		
13		* 1 to 60 min.	Time interval in minutes for the calculation of power intervals 0 = Interval controlled via the bus	For external synchronization, the value displayed is not relevant

Examples

Example 1: Programming the system configuration
(3-line, unbalanced load)

- Press > 2 s
- Press (present setting is displayed)
- Press (alterable parameter flashes)
- Press / to select desired setting

- Press (takes over new setting).
Display stops flashing.
- Press > 2 s to return to display level

Example 2: Programming voltage transformer ratio and synchronization interval

- Press > 2 s
- Press (transformer ratio menu)

3. Press (present setting of primary voltage)

UALL
P.P.P.P
8.500

4. Press (leftmost digit flashes)

UALL
P.P.P.P
8.500

5. Press / until desired number appears

6. Press (middle digit flashes)

7. Press / until desired number appears

8. Press (rightmost digit flashes)

9. Press / until desired number appears

10. Press (decimal point flashes)

11. Press / until the decimal point is on the desired position and the kilo/Mega display is correct

12. Press (takes over new value).
The display stops flashing

13. Press (present setting of secondary voltage)

UALL
5E00
8.500

14. Programming procedure same as for primary voltage (1 to 12)

15. Press until the topmost display

NEAU as shown

16. Press three times

NEAU
5400
E.P.P.E

17. Press (present setting of synchronization interval in minutes)

5400
E.P.P.E
8015

18. Press (left digit flashes)

5400
E.P.P.E
8015

19. Press / until desired number appears

20. Press (right digit flashes)

21. Press / until desired number appears

22. Press (takes over new value).
The display stops flashing

23. Press > 2 s (return to display level)

Konformitätserklärung / Certificat de conformité / Declaration of conformity

SINEAX A 210



EG - KONFORMITÄTserklärung
DECLARATION OF CONFORMITY

CAMILLE BAUER

Dokument Nr./
Document No.: A210.D0C

Hersteller/
Manufacturer: Camille Bauer AG
Switzerland

Anschrift /
Address: Aargauerstrasse 7
CH-5610 Wohlen

Produktbezeichnung/
Product name: Multifunktionales Leistungsmessgerät
Multifunctional Power Monitor

Typ / Type: SINEAX A 210

Das bezeichnete Produkt stimmt mit den Vorschriften folgender Europäischer Richtlinien überein, nachgewiesen durch die Einhaltung folgender Normen:

The above mentioned product has been manufactured according to the regulations of the following European directives proven through compliance with the following standards:

Nr. / No.	Richtlinie / Directive
89/336/EWG 89/336/EEC	Elektromagnetische Verträglichkeit - EMV - Richtlinie Electromagnetic compatibility -EMC directive

EMV / EMC	Fachgrundnorm / Generic Standard	Messverfahren / Measurement methods
Störaussendung / Emission	CN 50 081 2 : 1993	CN 55011 : 1996 + A1 : 1999
Störfestigkeit / Immunity	CN 61000-8-2 : 2001	IEC 81000-4-2 : 1995+A1 : 1998+A2:2000 IEC 81000-4-3 : 1995+A1 : 1998+A2:2000 IEC 81000-4-4 : 1995+A1 : 2000 IEC 81000-4-5 : 1995+A1 : 2000 IEC 81000-4-6 : 1995+A1 : 2000 IEC 81000-4-8 : 1995+A1 : 2000 IEC 81000-4-11 : 1994+A1 : 2000

Nr. / No.	Richtlinie / Directive
73/23/EWG /73/23/EEC	Elektrische Betriebsmittel zur Verwendung innerhalb bestimmter Spannungsgrenzen - Niederspannungsrichtlinie - CE Kennzeichnung : 95 Electrical equipment for use within certain voltage limits - Low Voltage Directive - Attachment of CE mark : 95

CN/Norm/Standard	IEC/Norm/Standard
EN 61 010-1 : 1993	IEC 1010-1 : 1990 + A1 : 1992

Ort, Datum /
Place, date: Wohlen, den 11. Juni 2002

Unterschrift /
Signature: M.Ulrich

Signature: M. Ulrich

This product has been certified, that the manufacturer and the general public are informed, except for the responsibility of the manufacturer, that the product complies with the requirements of the following standards:

This product has been certified compliance with the requirements of the following standards, except for the responsibility of the manufacturer, that the product complies with the requirements of the following standards:

Kurzanleitung zum Ändern der Parameter

- In der Parameter-Ebene Taste **(P)** drücken
- Einstellbare 7-Segmentanzeige(n) **B** blinkt
- Mit Taste **↓** oder **↑** den blinkenden Inhalt einstellen.
Einstellbare Werte siehe Legende zu Diagramm (**1** bis **13**), abgebildet sind Default-Werte
- Taste **(P)** drücken.

Falls die nächste 7-Segmentanzeige, **B** der Dezimalpunkt oder eine Masseinheit **k** blinkt: Zurück zu Punkt 3.

- Mit Taste **↓** oder **↑** zum nächsten Parameter wechseln. Weiter mit Punkt 2.
oder
mit Taste **↑** zurück in die Menü-Ebene. Weiter mit Punkt 1.

Rückkehr in die Messwert-Anzeige:

(P)-Taste länger als 2 Sekunden drücken

Instruction abrégée pour modifier les paramètres

- Au niveau paramètres appuyer la touche **(P)**
- L'affichage à 7 segments respectif clignote **B**
- Avec les touches **↓** ou **↑** ajuster les valeurs clignotantes, voir légende aux diagrammes (**1** à **13**), les valeurs en défaut sont illustrées
- Appuyer la touche **(P)**.

Si un autre affichage à 7 segments **B**, ou un point décimal ou une unité de mesure **k** clignote retour au point 3.

SINEAX A 220



EG - KONFORMITÄTserklärung
DECLARATION OF CONFORMITY

CAMILLE BAUER

Dokument Nr./
Document No.: A220.D0C

Hersteller/
Manufacturer: Camille Bauer AG
Switzerland

Anschrift /
Address: Aargauerstrasse 7
CH-5610 Wohlen

Produktbezeichnung/
Product name: Multifunktionales Leistungsmessgerät
Multifunctional Power Monitor

Typ / Type: SINEAX A 220

Das bezeichnete Produkt stimmt mit den Vorschriften folgender Europäischer Richtlinien überein, nachgewiesen durch die Einhaltung folgender Normen:

The above mentioned product has been manufactured according to the regulations of the following European directives proven through compliance with the following standards:

Nr. / No.	Richtlinie / Directive
89/336/EWG 89/336/EEC	Elektromagnetische Verträglichkeit - EMV - Richtlinie Electromagnetic compatibility -EMC directive

EMV / EMC	Fachgrundnorm / Generic Standard	Messverfahren / Measurement methods
Störaussendung / Emission	CN 50 081 2 : 1993	CN 55011 : 1996 + A1 : 1999
Störfestigkeit / Immunity	CN 61000-8-2 : 2001	IEC 81000-4-2 : 1995+A1 : 1998+A2:2000 IEC 81000-4-3 : 1995+A1 : 1998+A2:2000 IEC 81000-4-4 : 1995+A1 : 2000 IEC 81000-4-5 : 1995+A1 : 2000 IEC 81000-4-6 : 1995+A1 : 2000 IEC 81000-4-8 : 1995+A1 : 2000 IEC 81000-4-11 : 1994+A1 : 2000

Nr. / No.	Richtlinie / Directive
73/23/EWG /73/23/EEC	Elektrische Betriebsmittel zur Verwendung innerhalb bestimmter Spannungsgrenzen - Niederspannungsrichtlinie - CE Kennzeichnung : 95 Electrical equipment for use within certain voltage limits - Low Voltage Directive - Attachment of CE mark : 95

CN/Norm/Standard	IEC/Norm/Standard
EN 61 010-1 : 1993	IEC 1010-1 : 1990 + A1 : 1992

Ort, Datum /
Place, date: Wohlen, den 7. März 2003

Unterschrift /
Signature: M.Ulrich

Signature: M. Ulrich

This product has been certified, that the manufacturer and the general public are informed, except for the responsibility of the manufacturer, that the product complies with the requirements of the following standards:

This product has been certified compliance with the requirements of the following standards, except for the responsibility of the manufacturer, that the product complies with the requirements of the following standards:

- A l'aide des touches **↓** ou **↑** passer au paramètre suivant.
Continuer avec point 2.
ou
par la touche **↑** retourner au niveau Menu. Continuer avec point 1.

Retour à l'affichage des valeurs de mesure en appuyant la touche **(P)** pour plus de 2 secondes.

Brief operating instruction for parameter modification

- On the parameter level press key **(P)**
- Adjustable 7-segment display **B** flashes
- Use **↓** or **↑** to set the flashing content.
Adjustable values see **1** to **13** in the parameter overview. All values shown are default values
- Press key **(P)**.

If there is still a flashing 7-segment digit **B**, decimal point or unit **k**: Back to 3.

- Change to the next parameter by pressing **↓** or **↑** and go back to 2.
or
go back to menu level with **↑** and go on with 1.

Return to measurands display:

Press **(P)** for more than 2 seconds.

Anzeige-
Ebene

Niveaux
d'affichage

Display
level

Menü-
Ebene

Niveaux
du menu

Menu
level

Parameter-
Ebene

Niveaux du
paramètre

Parameter
level

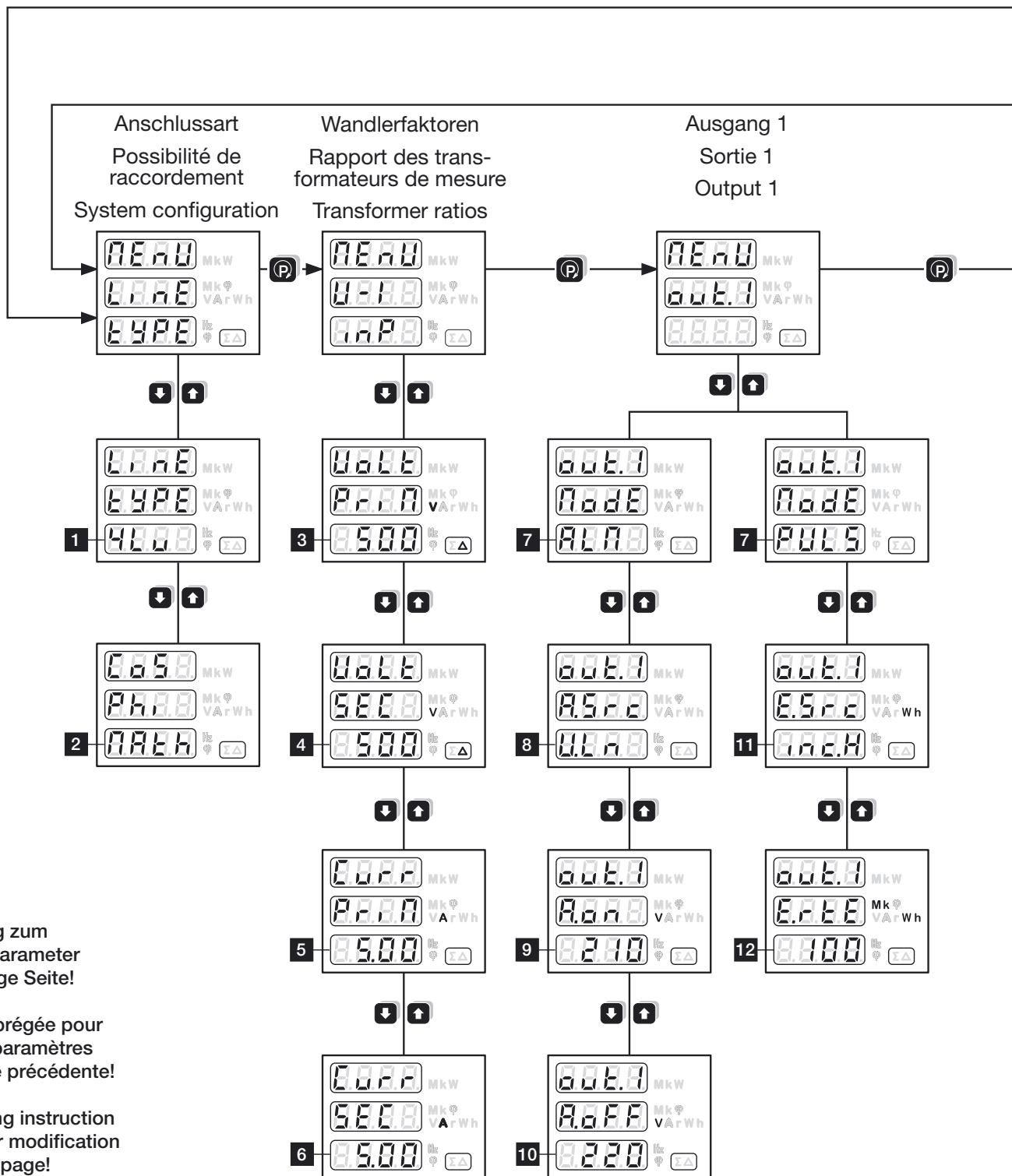

Messwert-Anzeige
Affichage des valeurs de mesure
Measurands display

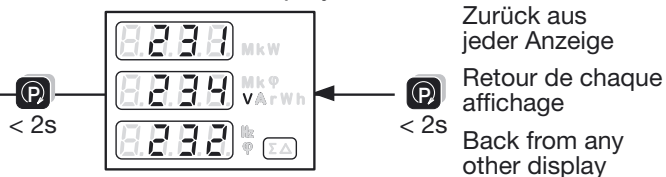

Ausgang 2
Sortie 2
Output 2

Leistungs-Intervall
Intervalle de puissance
Power interval

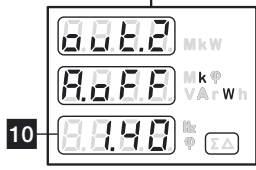
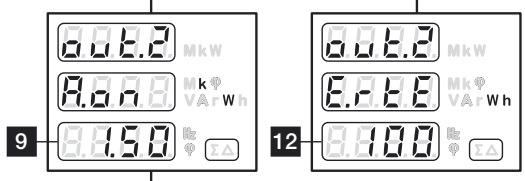
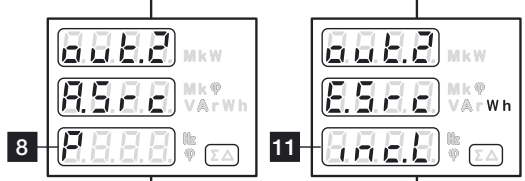
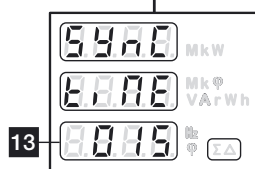
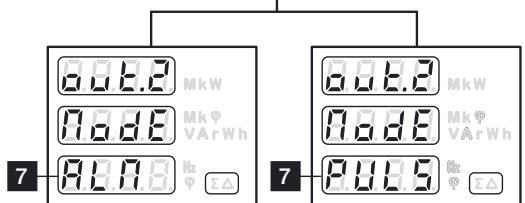
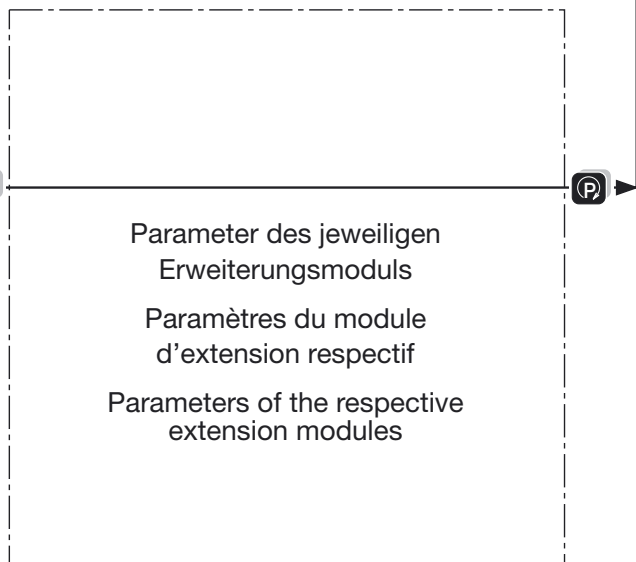
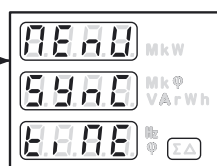
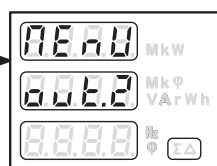

Masszeichnung / Croquis d'encombrement / Dimensional drawing SINEAX A 210

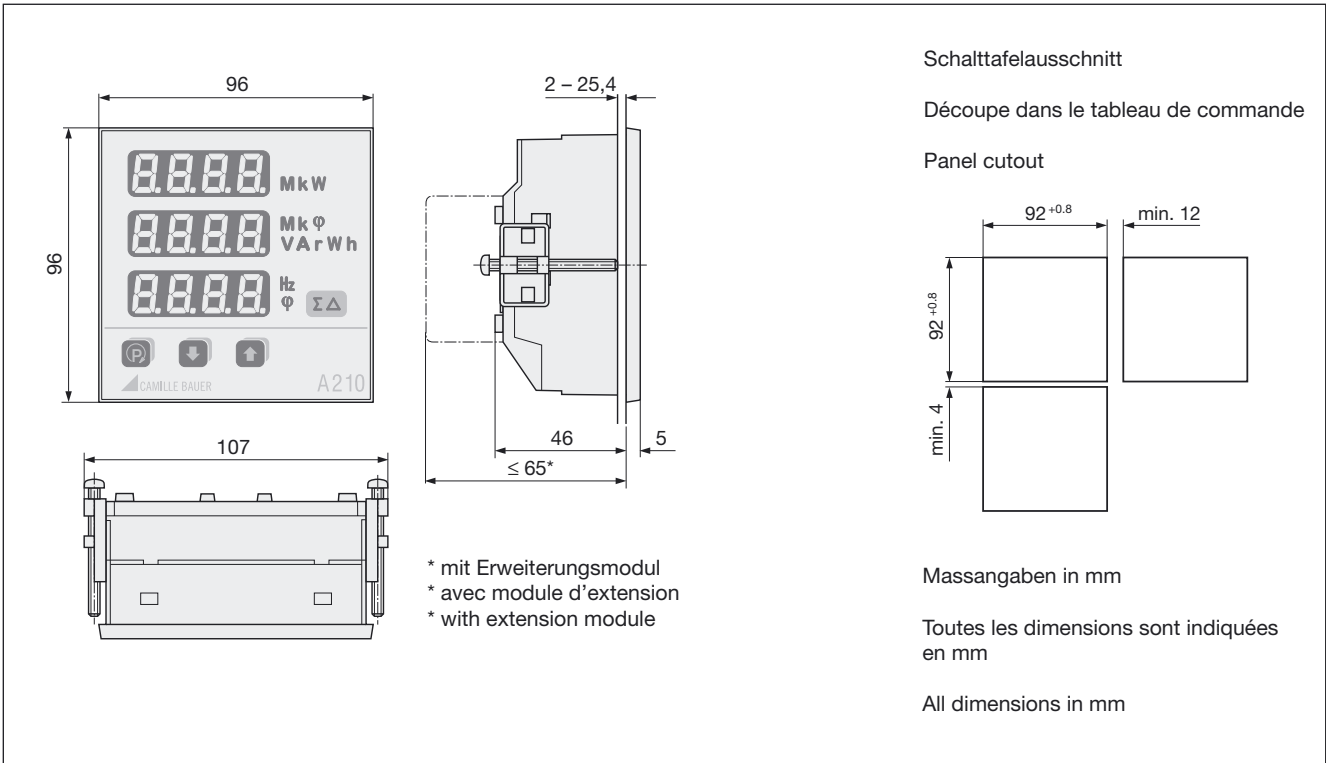

Masszeichnung / Croquis d'encombrement / Dimensional drawing SINEAX A 220

