



PEWA  
Messtechnik GmbH  
Weidenweg 21  
58239 Schwerte  
Tel.: 02304-96109-0  
Fax: 02304-96109-88  
E-Mail: info@pewa.de  
Homepage: www.pewa.de

**MAH 500**

**Multi-Contact**

**MC**

STÄUBLI GROUP

Typ / Type **SL205-K**

Best.-Nr. / Order No.  
No de cde **65.9182-\***



\* Farbcode gemäss Katalog  
Colour code see catalogue  
Code couleur voir catalogue

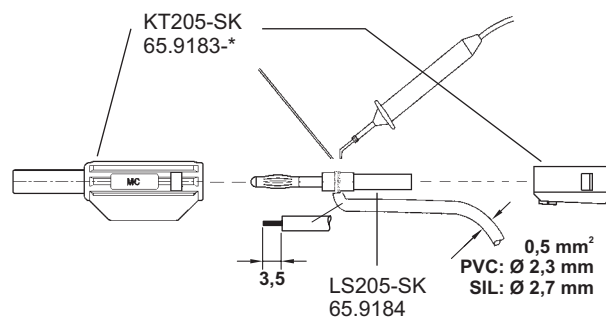

MAH 500 - index b