

DET4 Series

4-Terminal Earth/Ground Resistance and Soil Resistivity Testers



PEWA
Messtechnik GmbH
Weidenweg 21
56239 Schwerte
Tel.: 02304-96109-0
Fax: 02304-96109-88
E-Mail: info@pewa.de
Homepage: www.pewa.de



- **2, 3 and 4 point testing**
- **Stakeless (clamp-on) testing capability**
- **ART (Attached Rod Technique) capability**
- **Multiple, user selectable test frequencies**
- **Resistance measurement range to 200,000 Ω**
- **IP54 rated**
- **Warning indicators prevent test failure**
- **Simple one button operation**
- **Included leads, stakes, calibration certificate and rugged carry case**

DESCRIPTION

Megger's popular 4-terminal ground testing instrument family includes four basic models with different kit variants for each that include select accessories for greater testing flexibility. The four basic units are:

Model	Description
DET4TD2	Dry-cell battery powered basic 4-terminal tester
DET4TR2	Rechargeable battery powered basic 4-terminal tester
DET4TC2	Dry-cell battery powered 4-terminal tester with selectable test frequencies, greater measurement sensitivity and attached rod technique and stakeless measurement capability
DET4TCR2	Rechargeable battery powered 4-terminal tester with selectable test frequencies, greater measurement sensitivity and attached rod technique and stakeless measurement capability

The top-end models (DET4TC2 and DET4TCR2) include a current measuring function for ART (Attached Rod Technique) testing capabilities. With this added function, on-site grounds can be tested separately without having to remove the utility connection (as explained further in this document). They also provide stakeless testing capability. This method allows the operator to use the instrument like a clamp-on ground tester in applications where that method is viable, while also being able to operate as a fall of potential tester if required.

The basic kit includes the test leads, stakes, batteries and calibration certificate, delivered in a tough polypropylene carry case – everything you need to start testing in one package.

All models are rated to IP54, making them truly outdoor instruments. They are designed to meet stringent safety standards and are rated CAT IV 100 V. The ground testers have been designed to be easy to use – a large selector switch makes selection of 2, 3 or 4 pole tests easy with gloved hands – and the design makes the fitting of shorting links to perform 2-pole tests a thing of the past. A large, clear, easy to read LCD and thumb sized test button also make the instruments particularly well suited to the outdoor conditions of ground testing. In addition to this ease of use feature, the instruments automatically check the connection and conditions of the P spike, C spike, and also the level of ground noise, indicating the status on the display. They also include a voltmeter to enable measurement of ground voltage.

The DET4TD2 and DET4TR2 can measure resistance from 0.01 ohms to 20 kΩ, while the DET4TC2 and DET4TCR2 can measure resistance from 0.01 ohms to 200 kΩ, a key capability for soil resistivity testing. Also, to allow accurate testing in noisy environments, the instruments are capable of rejecting noise up to 40 V peak to peak.

The DET4TD2 and DET4TC2 are powered by eight AA batteries which are widely available and also give excellent testing time – the status of these batteries is given by a bar graph on the LCD display, allowing the operator to decide when to change the batteries before they expire. The DET4TR2 and DET4TCR2 are powered from rechargeable

AA cells. The battery charger is built in and the instrument is supplied with an AC/DC adapter. For all instruments, the battery status is displayed using a bar-graph.

The DET4TC2 and DET4TCR2 include additional capabilities. By using the optional ICLAMP the user can augment the traditional fall-of-potential measurement method with ART (Attached Rod Technique), which allows electrode testing without disconnection and also leakage current measurements down to 0.5 mA. A second optional clamp, the VCLAMP, enables true stakeless (clamp-on) measurements to be made in situations where driving stakes is not practical.

The DET4TC2 and DET4TCR2 also feature a backlit display, which extends the operational environment of the instrument to cable cellars and other dark locations. Finally, all units have selectable 25 V or 50 V output for compliance with IEC 61557-5. The 25 V output is required for testing in agricultural environments.



Model DET4TCR2 shown performing the stakeless ground testing method using only clamps.

APPLICATIONS

Proper grounding provides many varied benefits to both people and facilities. It lessens the chance of injury due to faulty installation, reduces the likelihood of damage from lightning strikes and induced voltages, improves the performance of computer, communication and other sensitive equipment and protects against static electricity from friction. Over time, ground systems can degrade or become ineffective. Corrosion and weather influences exert mechanical strain on ground rods and cause metallic corrosion. Catastrophic events like lightning strikes or large fault currents can cause instant degradation. In addition, soil resistivity can change over time due to environmental conditions and facility expansion can create different ground system needs.

The risks from ground system deterioration include potentially deadly electrical shock situations, plant-wide equipment damage, disruption in the performance of sensitive equipment and heat build-up on a single piece of electrical equipment.

The maintenance of an adequate low resistance ground connection is essential to both the protection and performance of any electrical system. Ground testing should be performed both upon installation, to meet design specification, and periodically thereafter in order to maintain service. All Megger models can also perform bonding tests (using an ac signal), to determine that adequate connection has been made from equipment to the grounding system, and can perform soil resistivity tests. This additional function can be used in prospecting, locating, and designing new grounding electrodes and systems. Furthermore, the addition of built-in current clamp capability enables fall of potential testing of attached grounds (ART) without lifting the utility connection and the addition of voltage clamp technology enables stakeless testing from the same instrument.

Grounding electrodes from simple to complex systems can be tested, including:

- Primary and secondary electrical grounding systems
- Utility pole grounds
- Lightning protection systems
- Residential grounds
- Machinery safety grounds
- Computer and communication system grounds
- EMI/RFI system grounds
- Antenna and pedestal grounds
- CATV system grounds

FEATURES AND BENEFITS

- **Stakeless testing** capability, which allows the operator to use the instrument like a clamp-on tester in applications where the method is viable
- **Attached Rod Technique** capability, which allows fall of potential testing without the need to disconnect the ground rod
- Multiple, user selectable test frequencies allows the operator to find the most effective frequency for making the measurement
- 200,000 Ω measurement range provides the ability to measure the resistivity of any type of soil
- User selectable test voltage ensures that the units can be used in agricultural environments
- Microprocessor control for improved error detection
- Clear, unambiguous warnings and error indications ensure the reliability of the reading and reduce test time
- Rugged, weatherproof case to IP54 makes the units truly outdoor instruments
- Backlit LCD allows for testing in dark environments
- Noise rejection to 40 V pk to pk allows accurate testing in noisy environments
- Testing kits and certificates supplied — everything needed to start testing immediately
- Accuracy of 2% of reading enhances reliability of measurements
- Voltmeter function included allows you to measure the ground voltage and enhances operator safety
- CAT IV 100V provides increased operator safety

SPECIFICATIONS

Resistance range: 0.01 to 200 kΩ autoranging
(0.01 to 20kΩ for models DET4TD2 and DET4TR2)

Resistance accuracy:

- 2P measurements 2% ±3 digits
- 3P measurements 2% ±3 digits
- 4P measurements 2% ±3 digits
- ART measurements 5% ±3 digits
- Stakeless measurements 7% ±3 digits

Maximum probe resistance:

DET4TD2 and DET4TR2

- Rp limit: 100kΩ (50V output voltage)
- Rc limit: 100kΩ (50V output voltage)
- Limits reduced to 50kΩ for 25V output voltage
- Limits reduced to 5kΩ for 0.01 Ω resolution

DET4TC2 and DET4TCR2

- Rp limit: 200kΩ (50V output voltage)
- Rc limit: 200kΩ (50V output voltage)
- Limits reduced to 100kΩ for 25V output voltage
- Limits reduced to 5kΩ for 0.01 Ω resolution

Earth voltage range: 0 – 100 V

Earth voltage accuracy: 2% ±2 V

2-wire test: Yes, all models

3-wire test: Yes, all models

4-wire test: Yes, all models

ART (Attached Rod Technique): DET4TC2, DET4TCR2

Stakeless test: DET4TC2 and DET4TCR2

Ground current range (with current measuring clamp):

0.5 mA to 19.9 A

Ground current accuracy: 5% ±3 digits

Display:

DET4TD2 and DET4TR2: 3-1/2 digit high contrast LCD

DET4TC2 and DET4TCR2: 3-1/2 digit high contrast LCD, backlit

Test frequency: 94, 105, 111 and 128 Hz
(128 Hz for DET4TD2 and DET4TR2)

Test voltage: 25 V or 50 V, user selectable (factory setting 50 V)

Test current: 450 micro-amps at 25 V or 50 V (selectable), 4.5 mA at 25 V

Noise rejection: 40V pk to pk

Noise check: Automatic

C spike check: Automatic

P spike check: Automatic

Battery type: 8 1.5 V AA cells (8 1.5 V AA NiMH rechargeable cells – DET4TR2 and DET4TCR2)

Battery life: 3 hours, 700 consecutive tests

Safety: EN61010-1 CAT IV 100 V

Terminals: 4 mm plug type (test leads)

Ingress protection: IP54

EMC: Meets the requirements of EN61326-1:1998 for use in heavy industrial areas, including amendment 1

Dimensions: 8 x 5.7 x 3.2 in. (203 x 148 x 78 mm)

Weight: 2.2 lb (1 kg)

Operating temperature range: 5° to +131° F (-15° to +55° C)

Storage temperature range: -40° to +158° F (-40° to +70° C)

Humidity: 95% RH non-condensing at 104° F (40° C)

Standards Compliance

Complies with the requirements of KEMA K85B.

Complies with the following parts of EN61557, “Electrical safety in low voltage distribution systems up to 1000 V a.c. and 1500 V d.c. - Equipment for testing, measuring or monitoring of protective measures”.

Part 1 - General requirements

Part 5 - Resistance to earth

STAKELESS (CLAMP-ON) TESTING

The DET4TC2 and DET4TCR2 include stakeless, or clamp-on testing capability. In effect, these models can be operated in the same way as a clamp-on ground tester, eliminating the need to disconnect the ground under test and drive test probes in certain ground system testing applications. This method is also useful when

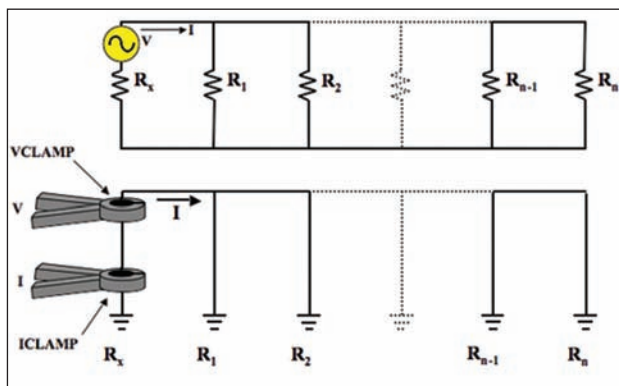

there is insufficient space to perform a classic fall-of-potential measurement. In addition the units can be used to measure ground leakage or phase current.

The user simply clamps the optional ICLAMP (current clamp) and VCLAMP (voltage clamp) around the ground under test in the manner prescribed in the operator’s manual and takes the reading. A defined test voltage is injected into the system using the VCLAMP, inducing a current, I, to flow and be measured by the ICLAMP. The instrument then calculates the approximate resistance of the ground under test.

The stakeless method is subject to the same limitations faced by the traditional clamp-on ground tester. It is effective only in situations with multiple grounds in parallel and cannot be proofed like a fall-of-potential test. In situations where the stakeless method reading is questionable, a full fall-of-potential test is recommended. The advantage of the DET4TC2 and DET4TCR2 is that the units include both test methods in a single instrument, making them the most versatile units available.

**ART (ATTACHED ROD TECHNIQUE)
TESTING CAPABILITY**

The DET4TC2 and DET4TCR2 include the additional testing capability that we have termed **ART**, for **Attached Rod Technique**. A nagging problem with traditional ground testing has been the requirement to “lift” (i.e., disconnect) the utility connection. Once the grounding conductor (the main conductor that connects the facility to the ground rod or grid) has been attached to the grounding electrode, the utility ground becomes a parallel resistance. The utility neutral is typically bonded to the ground bus at the service entrance and this connection, during a ground test, causes test current to flow back through the utility ground as well as through the test electrode. Test current divides according to Law of Parallel Resistance, but the tester makes its measurement based on total current flow. The reading is the combined parallel resistance of the on-site ground and the utility protection. This is a valid measurement, but not of the test electrode exclusively.

This poses a considerable problem in many common testing situations. If a commissioning test were required to determine if design specifications had been met for a new facility, such a reading would be insufficient. Lightning protection requiring a short, straight path into the earth, could also not be properly validated. But lifting the utility connection poses several problems, not the least of which is the breaking of what is often a welded bond, in addition to the temporary loss of protection.

Clamp-on ground testers, which measure ground resistance by clamping around the rod and inducing a test current onto it, are only a limited solution. They can accurately measure resistance of a single rod in a parallel system by inducing the test current onto the clamped rod and utilizing all the parallel grounds as the return. Collectively, these returns, typically the multiple grounds of the utility, contribute little to the loop measurement. This is essentially the reverse of the operation of a traditional tester, which uses the current probe as the return while current “goes to ground” through all parallels collectively. This technique solves the problem of separately measuring an attached rod, but leaves the problem that it cannot be proven.

A clamp-on measurement has to be accepted on faith and its reliability is based squarely on the knowledge and experience of the operator, leaving a large margin for “human error.” In complex, multiply connected grids and other grounding schemes, return paths may exist that are entirely metallic, not including earth at all. The clamp-on test current will circulate through such paths and give a reading, essentially a continuity reading of the grid structure having nothing to do with soil resistance. Such readings will be low, and appear to the uninformed

as acceptable grounds. The responsibility for making these determinations falls squarely on the operator. But even when properly addressed, there is no way of demonstrating the competence of the readings to a third party, such as a client. They must simply be accepted.

The **ART** testing capability combines the advantages of both of these technologies to produce a method that can reliably measure an attached ground, and prove it! A built-in clamp input, used in conjunction with the optional ICLAMP accessory, connected below the point of separation of the parallel test currents, measures only the current flowing through the test ground, not that going back through the utility. This current value is then used by the microprocessor to calculate ground resistance, strictly in accordance with **Fall of Potential** or its derivative procedures, supported by IEEE Standard 81 for proper ground testing, and subject to the appropriate proofs.

The **ART** method employs leads and probes just as does any traditional tester. Ground resistance can be profiled and graphed by moving the potential probe against the position of the current probe, and a Fall of Potential graph, Slope Method mathematical proof, or any of the other proven methods utilized to demonstrate the accuracy of the test. The only thing different from the operation of a familiar, traditional ground tester is that the clamp permits separation of the test currents in an attached or otherwise parallel-grounded system. This technique enables local grounds to be tested without lifting the utility connection, yet with the ease, reliability and confidence of a separate commissioning test.



**Current measuring clamp (inset)
for ART testing capability**

SELECTION GUIDE	Model No.	DET4TD2	DET4TR2	DET4TC2	DET4TCR2	
	Cat. No.	1000-347	1000-324	1000-345	1000-346	
Tests	2-Pole Measurement	■	■	■	■	
	3-Pole Measurement	■	■	■	■	
	4-Pole Measurement	■	■	■	■	
	Soil Resistivity	■	■	■	■	
	ART (Attached Rod Technique) Capability			■	■	
	Stakeless (Clamp-on) Measurement Capability			■	■	
	Resistance Range	0.01 to 20,000 Ω		0.01 to 200,000 Ω		
	Ground Voltage Range	0 to 100 V				
	Ground Current Range (with ICLAMP) Capability			0.5 mA to 19.9 A		
Output	Selectable Voltage (25/50 V)	■	■	■	■	
	Test Frequency	128 Hz		94, 105, 111, 128 Hz		
Power Supply	Alkaline Batteries	■		■		
	Rechargeable Batteries		■		■	
Noise Rejection	40 V Peak-to-Peak	■	■	■	■	
Safety Rating	CAT IV 100 V	■	■	■	■	
Ingress Protection	Rated to IP54	■	■	■	■	
Included Accessories	Hard Carry Case	■	■	■	■	
	Test Leads (49 ft, 33 ft, 33 ft, 10 ft) and Spikes	■	■	■	■	
	Certificate of Calibration	■	■	■	■	
Warranty	3 Year	■	■	■	■	

CONFIGURATION OPTIONS

Model No.	Cat. No.	Included Accessories							Power Supply	
		Hard carry case	4 Right-angle terminal adapters	Leads (49 ft, 33 ft, 33 ft, 10 ft) and Spikes	External ac/dc Adapter	Field Calibrator	ICLAMP and VCLAMP	Earth/ground kit, C/N 6320-245	Alkaline batteries	Rechargeable batteries
DET4TC2+Clamps	1000-365	■	■	■		■	■		■	
DET4TC2+Kit	1000-404	■	■	■		■	■	■	■	
DET4TCR2+Clamps	1000-366	■	■	■	■	■	■			■
DET4TCR2+Kit	1000-405	■	■	■	■	■	■	■		■

*The Professional Ground Testing Kit (C/N 6320-245) includes two 164 ft (50 m) leads and two 98 ft (30 m) leads on retractable reels, four auger-style ground spikes, a tape measure and a separate hard carry case.

NOTE: Using the ICLAMP allows the operator to make ART measurements. Using the ICLAMP and VCLAMP allows the operator to make stakeless (clamp-on) measurements.

DET4TC2 OPERATION

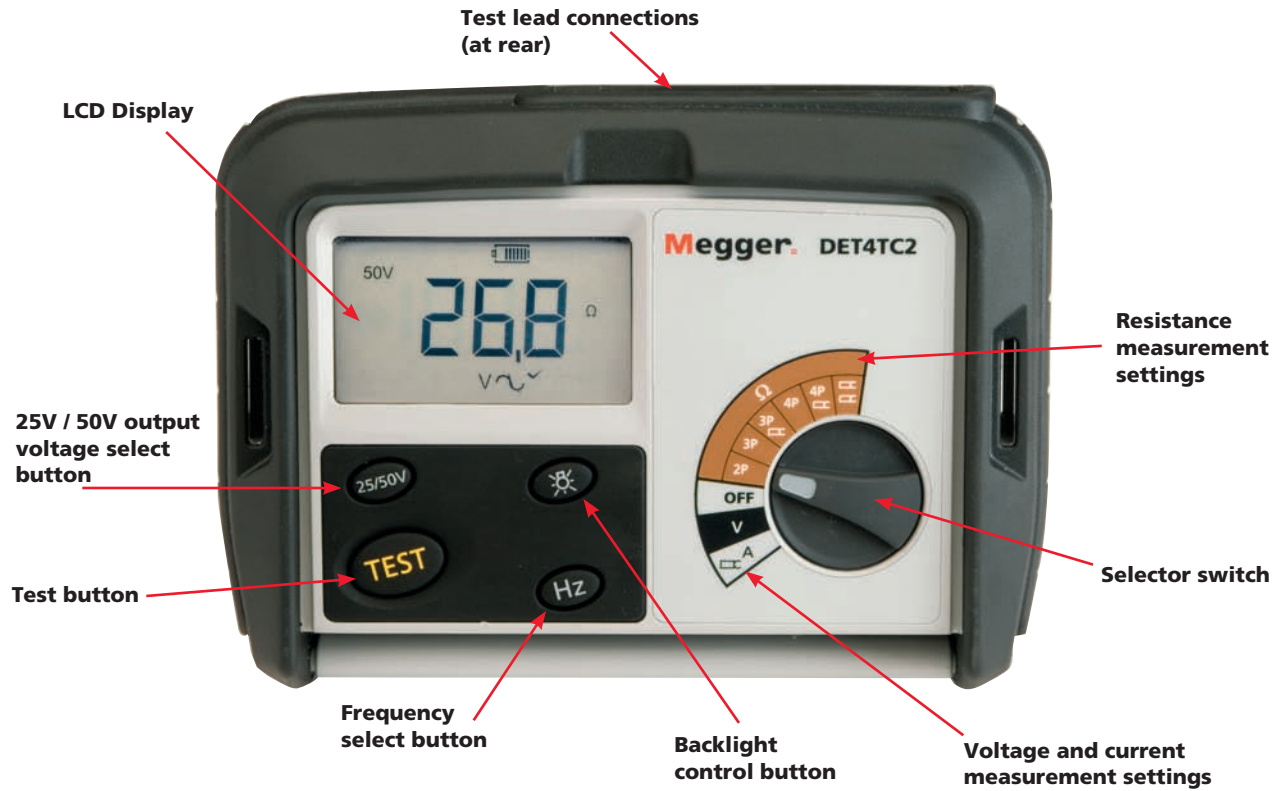

DET4TC2 DISPLAY EXAMPLE

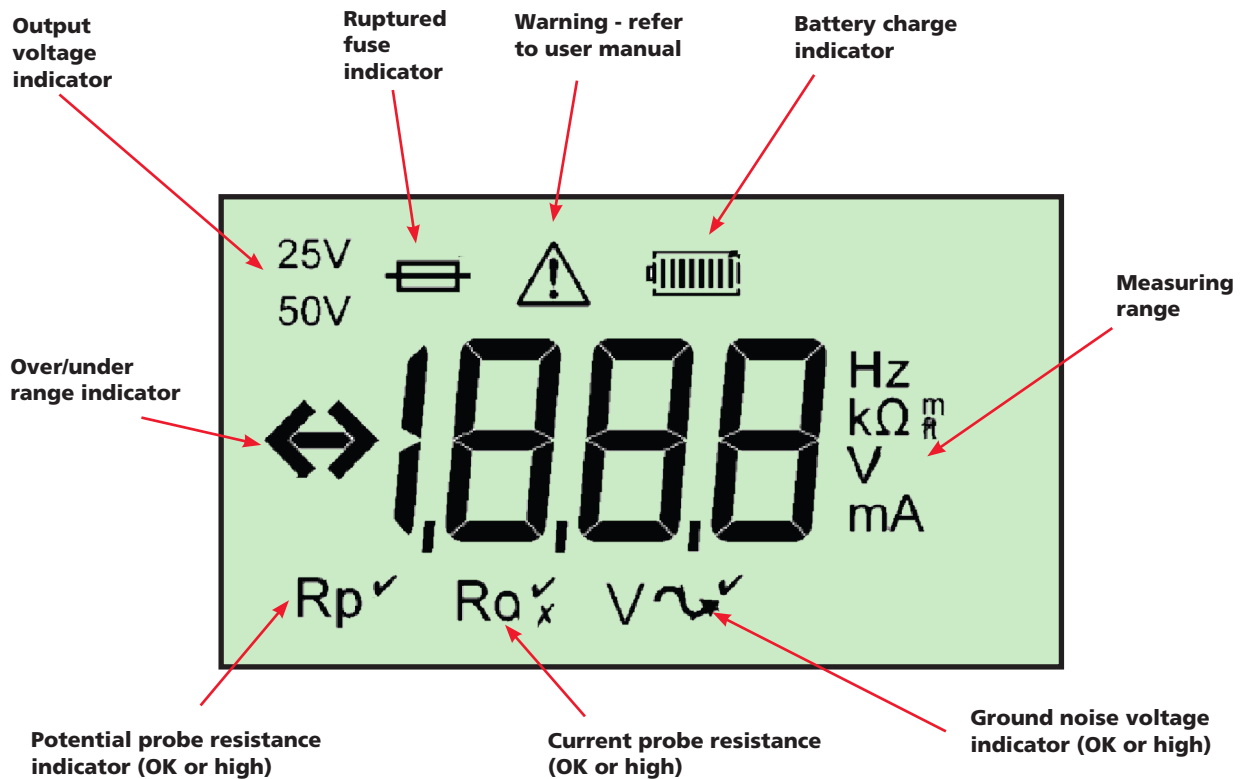



Each instrument comes complete with three sets of leads, two test spikes, instruction manual CD, and a rugged carrying case, (current measuring clamp, shown, is an optional accessory for performing the ART testing capability using the DET4TC2 and DET4TCR2 only.)



Terminal Adapters are used to allow the DET4 Series units' terminals to accept alternative cable connections.

OPTIONAL ACCESSORY KITS

**Professional Kit
Cat. No. 6320-245**

Red and black cable reels, 164 ft (50 m); yellow and green cable reels, 98 ft (30 m); earth electrode leads, 13 ft (4 m) green; 4 mm shrouded plug and large croc clip; 4 auger-style spikes; molded polyethylene carrying case; fiberglass measuring tape, 164 ft (50 m)



**Soil Resistivity Kit
Cat. No. 250586**

Set of four test leads, 50 ft. (15 m); two pair of 20 in. (51 cm) ground rods; padded case to hold instrument, leads and rods



**Deluxe Kit,
Cat. No. 250581**

Set of three color-coded test leads, 25, 50, 100 ft. (8, 15, 30 m); two 20-in. (51 cm) ground rods; padded case to hold instrument, leads and rods



**Standard Kit,
Cat. No. 250579**

Three color-coded test leads, 25, 50, 100 ft. (8, 15, 30 m); two 20-in. (51 cm) ground rods; canvas accessory case for leads and rods only



**Standard Kit
Cat. No. 6310-755**

Hammer, 2.5 lb (1.13 kg); four galvanized steel spikes, 0.5 in. (12 mm); two spike extractors; four leads in carrying case



ORDERING INFORMATION

Item (Qty)	Cat. No.	Item (Qty)	Cat. No.
DET4TD2	1000-347	Standard accessory kit (hammer, spikes, leads)	6310-755
DET4TR2	1000-324	Professional ground testing kit (2 x 50m, 2 x 30m, 4 auger stakes, carry case)	6320-245
DET4TC2	1000-345	Soil resistivity kit (leads, rods, padded case)	250586
DET4TC2+Clamps	1000-365	"Getting Down to Earth" a Megger guide to earth testing	AVTM25-TA
DET4TC2+Kit	1000-404	Replacement hard carry case	5410-429
DET4TCR2	1000-346	Replacement calibration check PCB (two-clamp measurements)	6220-831
DET4TCR2+Clamps	1000-366	Replacement ground test stakes (x2) for included kit (200mm, 8mm dia)	6220-804
DET4TCR2+Kit	1000-405	Replacement ground test leads (x4) for included kit (15m, 10m, 10m, 3m)	6220-806
<i>See Configuration Options chart for detailed information</i>		Replacement auger stakes (x2) for professional kit	6220-839
Optional Accessories		Replacement cable reel (50m, red cable) for professional kit	6220-840
Current measuring clamp and connecting lead for ART testing method	ICLAMP	Replacement cable reel (50m, black cable) for professional kit	6220-841
Voltage inducing clamp, calibration check PCB (two-clamp measurements) and connecting lead	VCLAMP	Replacement cable reel (30m, green cable) for professional kit	6220-843
Calibration check box	6220-824	Replacement cable reel (30m, yellow cable) for professional kit	6220-842
Right angled terminal adaptor set	6220-803		
Auxiliary 12V socket charger (DET4TR2 and DET4TCR2 only)	6280-375		
Standard accessory kit (leads, rods, canvas accessory case for leads & rods)	250579		
Deluxe accessory kit (leads, rods, padded case)	250581		